

Application A 157-1

System Description:

The 157 operates the variable speed pump, P1, and adjusts its speed in order to maintain the ΔT Target; the difference in temperature between the source and storage.

Mechanical

P1 = Variable Speed Pump
 S1 = Source Sensor 085
 S2 = Storage Sensor 071

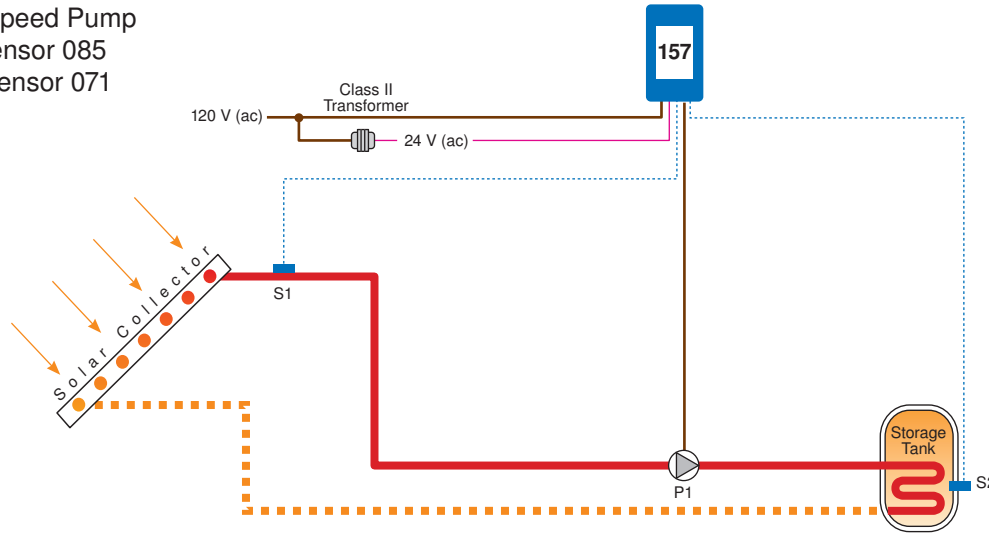

Electrical

P1 = Variable Speed Pump
 S1 = Source Sensor 085
 S2 = Storage Sensor 071

Essential Control Settings

Mode = Off (secondary pump off)

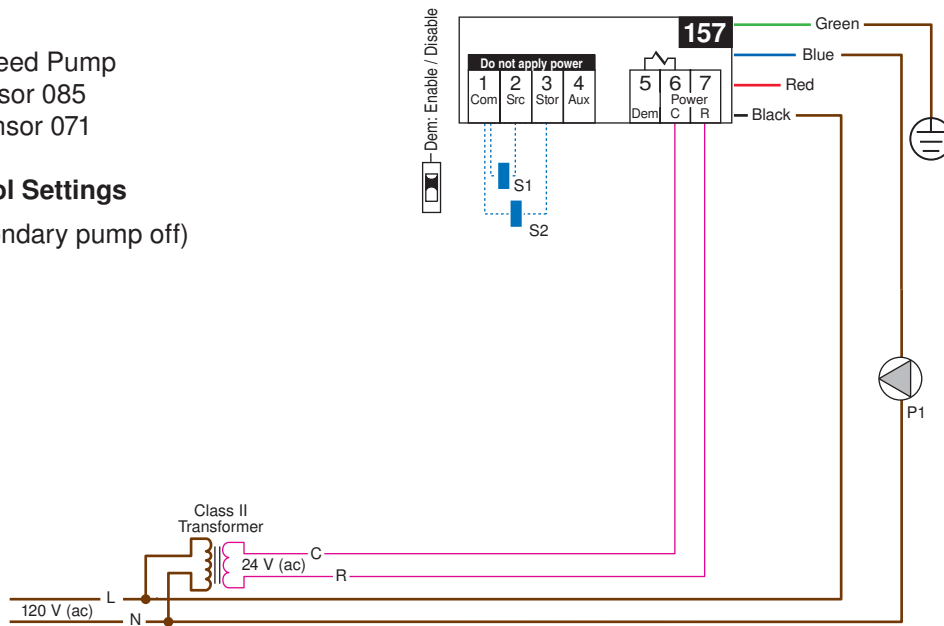

Concept Drawing: This is only a concept drawing, not an engineered drawing. It is not intended to describe a complete system, nor any particular system. It is up to the system designer to determine the necessary components for and configuration of the particular system being designed, including additional equipment, isolation relays (for loads greater than the control's specified output ratings), and any safety devices which in the judgement of the designer are appropriate, in order to properly size, configure and design that system and to ensure compliance with building and safety code requirements.

Application A 157-2

System Description:

The 157 operates the variable speed pump, P1, and adjusts its speed in order to maintain the ΔT Target. The secondary pump, P2, is turned on whenever P1 is above 0% output.

Mechanical

P1 = Variable Speed Pump
 P2 = Heat Exchanger Pump
 S1 = Source Sensor 085
 S2 = Storage Sensor 071

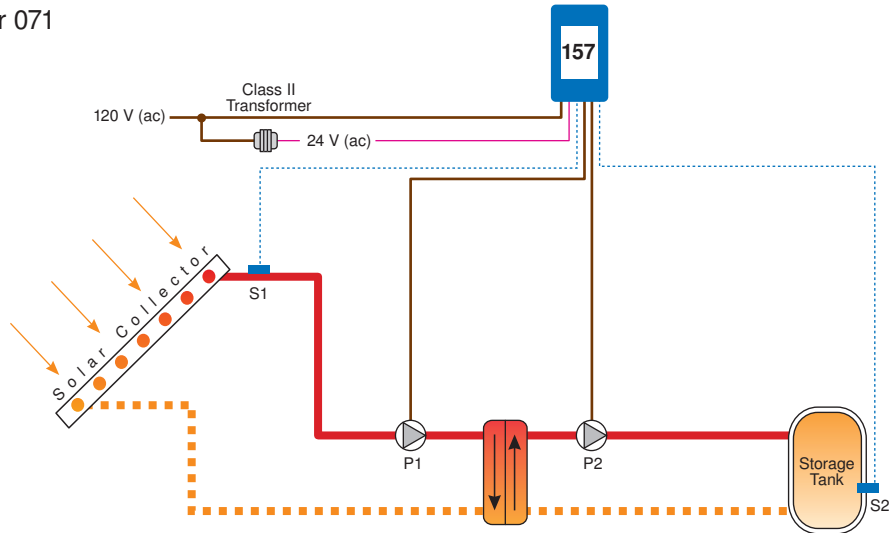

Electrical

P1 = Variable Speed Pump
 P2 = Heat Exchanger Pump
 S1 = Source Sensor 085
 S2 = Storage Sensor 071

Essential Control Settings

Mode = 1 (Heat Exchanger)

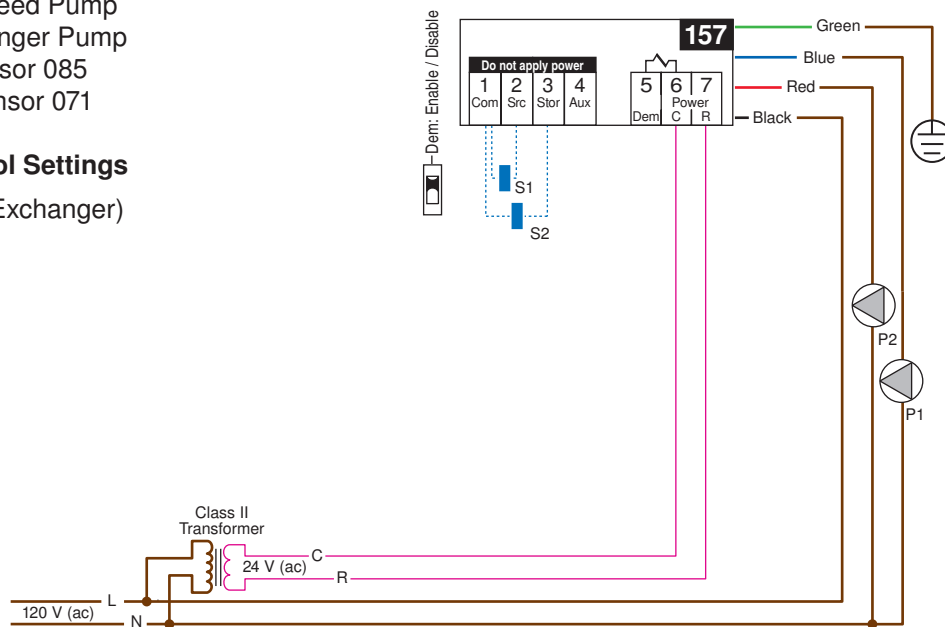

Concept Drawing: This is only a concept drawing, not an engineered drawing. It is not intended to describe a complete system, nor any particular system. It is up to the system designer to determine the necessary components for and configuration of the particular system being designed, including additional equipment, isolation relays (for loads greater than the control's specified output ratings), and any safety devices which in the judgement of the designer are appropriate, in order to properly size, configure and design that system and to ensure compliance with building and safety code requirements.

Application A 157-3

System Description:

The variable speed pump, P1, operates to maintain the ΔT Target until the storage temperature increases above the Max Storage Target. The supplemental heat pump, P2, operates in an on/off fashion to maintain the MIN Storage Target at the auxiliary sensor.

Mechanical

- P1 = Variable Speed Pump
- P2 = Heat Supplement Pump
- S1 = Source Sensor 085
- S2 = Storage Sensor 071
- S3 = Auxiliary Sensor 071

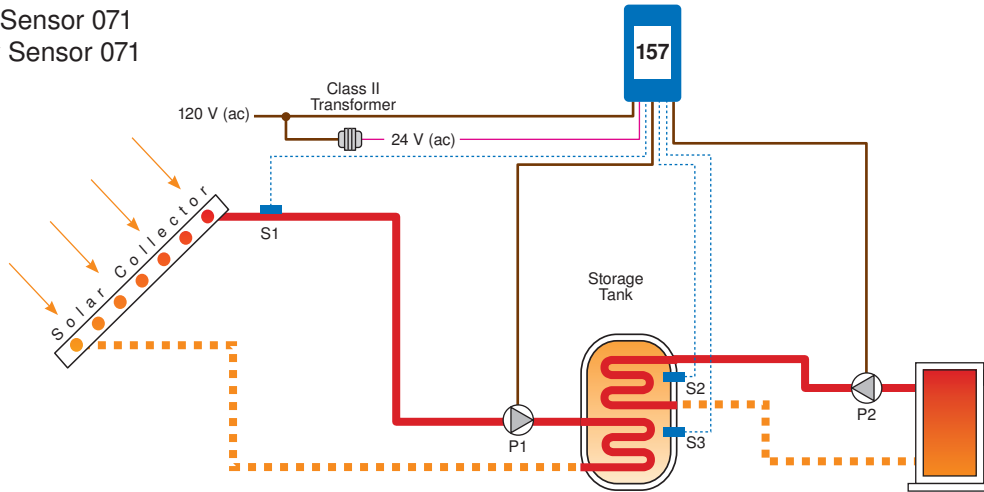

Electrical

- P1 = Variable Speed Pump
- P2 = Heat Supplement Pump
- S1 = Source Sensor 085
- S2 = Storage Sensor 071
- S3 = Auxiliary Sensor 071

Essential Control Settings

Mode = 2 (Heat Supplement)

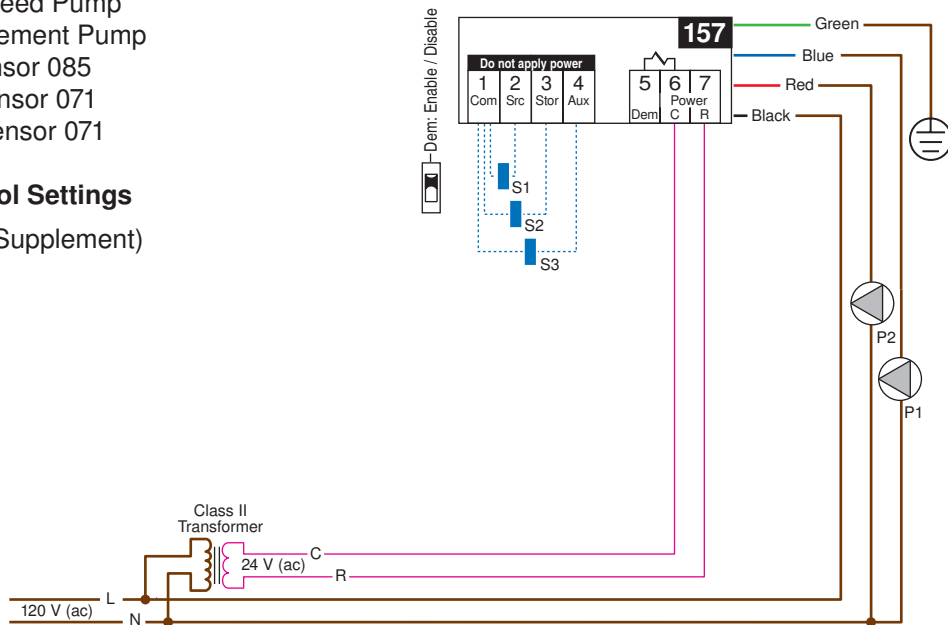

Concept Drawing: This is only a concept drawing, not an engineered drawing. It is not intended to describe a complete system, nor any particular system. It is up to the system designer to determine the necessary components for and configuration of the particular system being designed, including additional equipment, isolation relays (for loads greater than the control's specified output ratings), and any safety devices which in the judgement of the designer are appropriate, in order to properly size, configure and design that system and to ensure compliance with building and safety code requirements.

Application A 157-4

System Description:

The 157 operates the variable speed pump, P1, and adjusts its speed in order to maintain the ΔT Target. If the tank temperature reaches the Max Storage Target and the collector temperature reaches the Max Source Target, the 157 turns off the variable speed pump and turns on the heat dump pump, P2, to transfer the heat from the source to the heat sink. If the auxiliary sensor rises above the Auxiliary Max Target, P2 will shut off.

Mechanical

- P1 = Variable Speed Pump
- P2 = Heat Dump Pump
- S1 = Source Sensor 085
- S2 = Storage Sensor 071
- S3 = Auxiliary Sensor 071

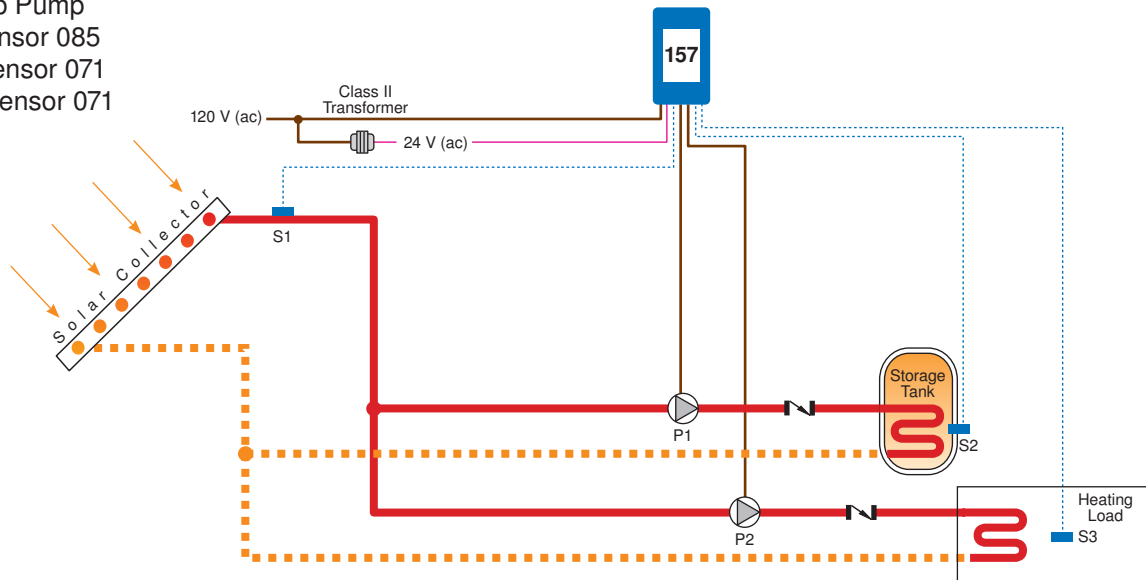

Electrical

- P1 = Variable Speed Pump
- P2 = Heat Dump Pump
- S1 = Source Sensor 085
- S2 = Storage Sensor 071
- S3 = Auxiliary Sensor 071

Essential Control Settings

Mode = 3 (Heat Dump)

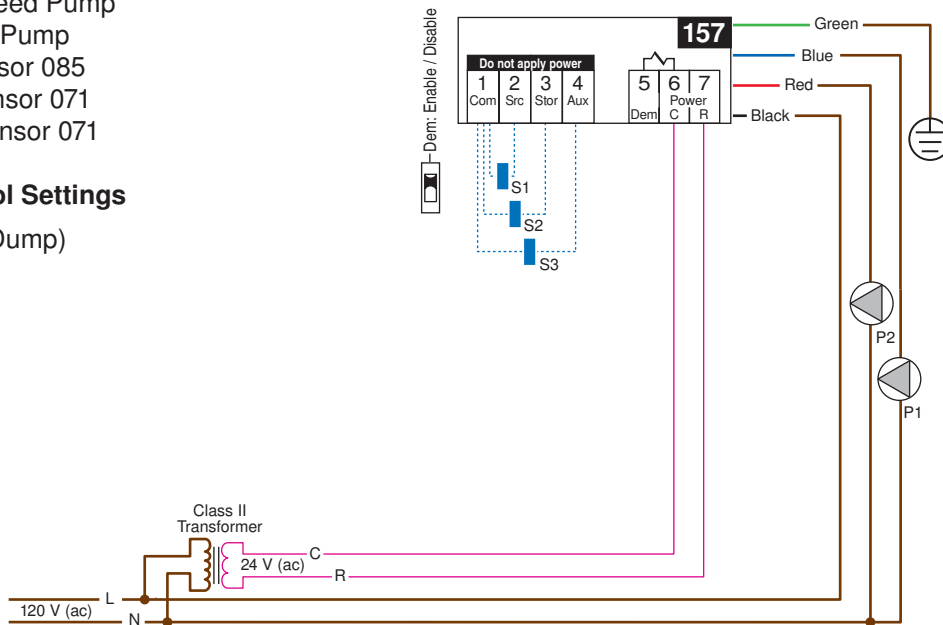

Concept Drawing: This is only a concept drawing, not an engineered drawing. It is not intended to describe a complete system, nor any particular system. It is up to the system designer to determine the necessary components for and configuration of the particular system being designed, including additional equipment, isolation relays (for loads greater than the control's specified output ratings), and any safety devices which in the judgement of the designer are appropriate, in order to properly size, configure and design that system and to ensure compliance with building and safety code requirements.

Application A 157-5

System Description:

The 157 turns on the variable speed pump, P1, and the booster pump, P2, at 100% output for an adjustable amount of time. After that time, the booster pump turns off and the 157 adjusts the speed of the variable speed pump in order to maintain the ΔT Target. Once the ΔT is below the Target less differential, the 157 turns off the variable speed pump and the water is drained back into the storage tank.

Mechanical

P1 = Variable Speed Pump
 P2 = Booster Pump
 S1 = Source Sensor 085
 S2 = Storage Sensor 071
 V1, V2 = Vents

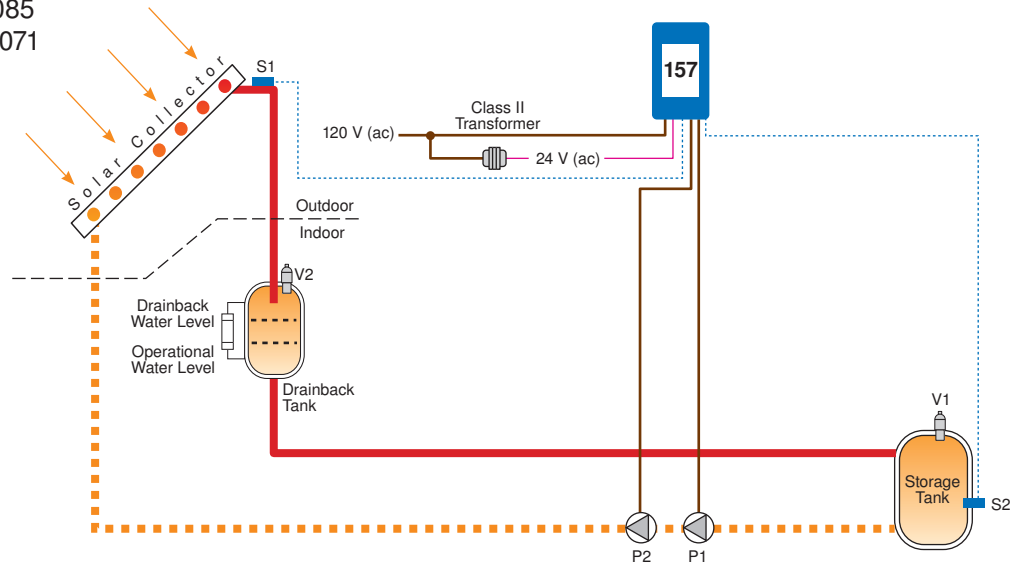

Electrical

P1 = Variable Speed Pump
 P2 = Booster Pump
 S1 = Source Sensor 085
 S2 = Storage Sensor 071

Essential Control Settings

Mode = 4 (Booster Pump)

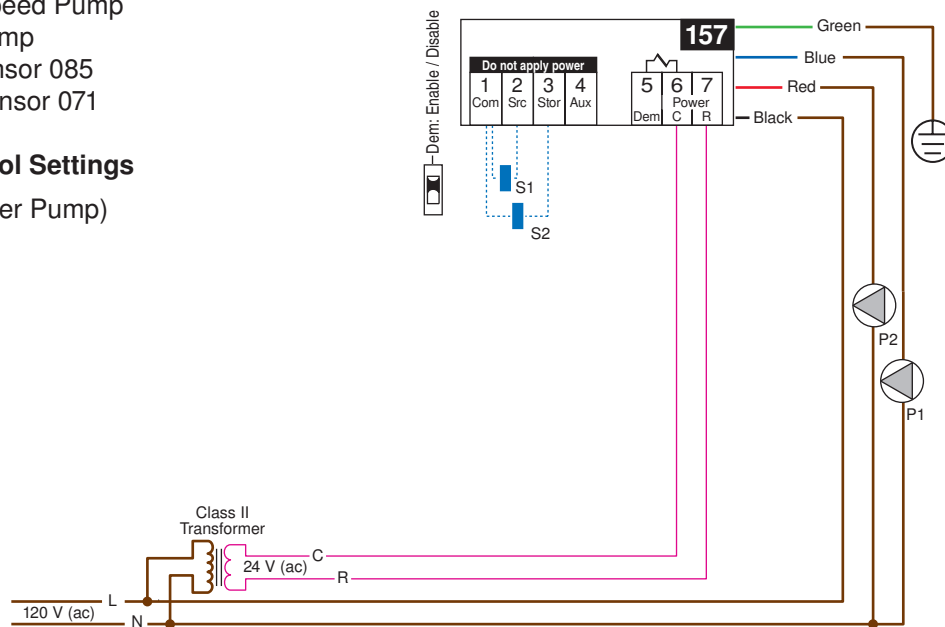

Concept Drawing: This is only a concept drawing, not an engineered drawing. It is not intended to describe a complete system, nor any particular system. It is up to the system designer to determine the necessary components for and configuration of the particular system being designed, including additional equipment, isolation relays (for loads greater than the control's specified output ratings), and any safety devices which in the judgement of the designer are appropriate, in order to properly size, configure and design that system and to ensure compliance with building and safety code requirements.

Application A 157-6

System Description:

The Boiler Control 274 provides outdoor reset to a space heating system and staging for a solar storage tank and single stage boiler. The solar storage tank and boiler are piped in primary-secondary to the heating load. The boiler pump is controlled by the 274 to allow for post purging of the boiler after it is shut off. The stage 1 relay on the 274 powers the enable demand on the 157. The 157 operates the on/off pump, P3, as long as the storage tank temperature is above the return heating loop temperature by the programmable difference setpoint.

Mechanical

- P1 = Primary Pump
- P2 = Boiler Pump
- P3 = Storage Tank Pump
- S1 = Boiler Supply Sensor 071
- S2 = Outdoor Sensor 070
- S3 = Storage Sensor 085
- S4 = Source Sensor 071

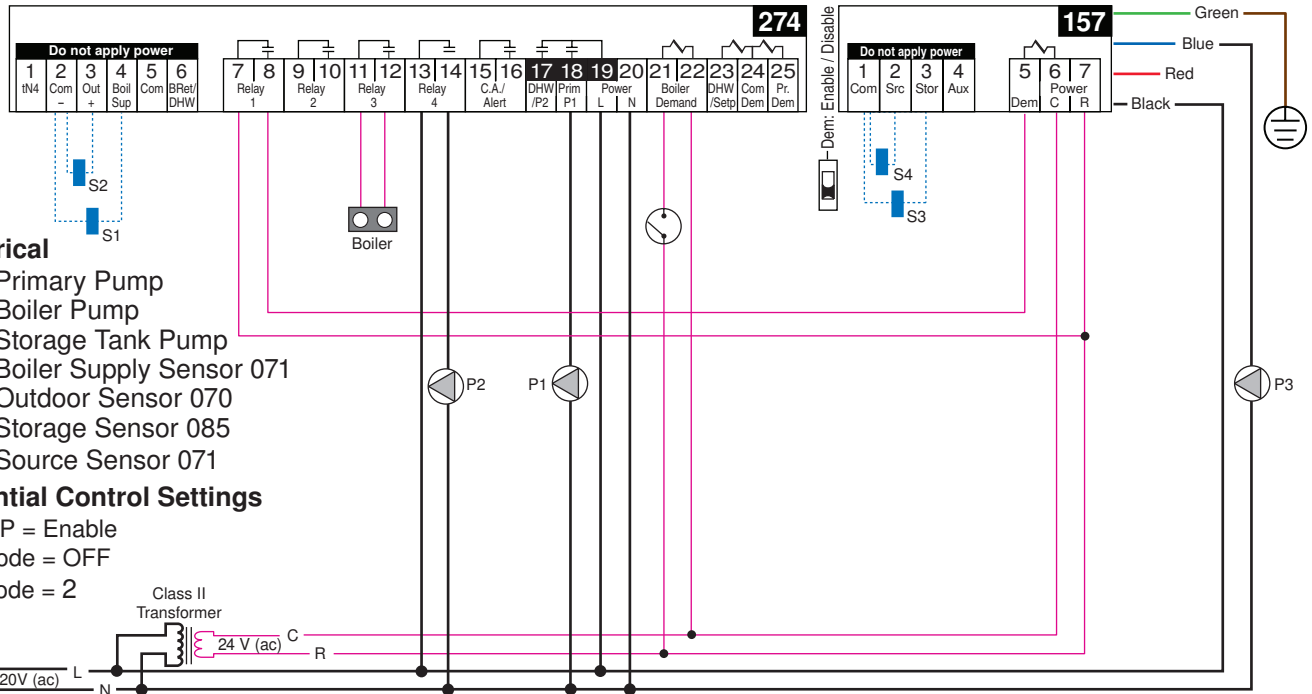
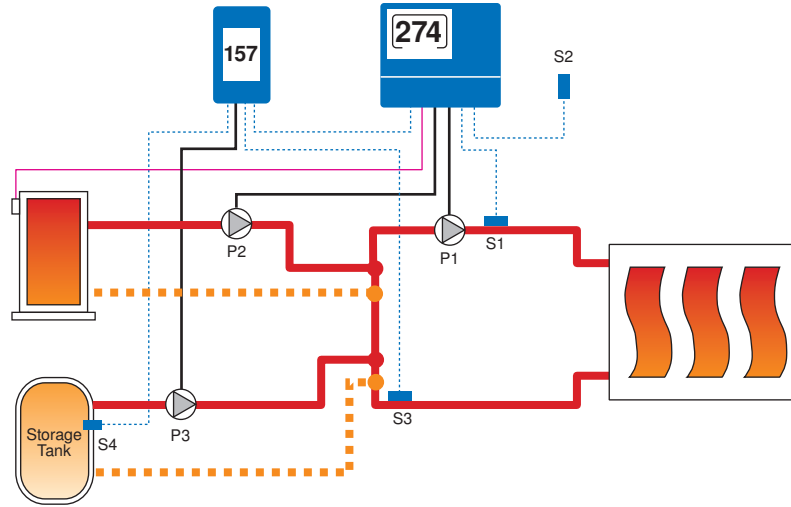

Electrical

- P1 = Primary Pump
- P2 = Boiler Pump
- P3 = Storage Tank Pump
- S1 = Boiler Supply Sensor 071
- S2 = Outdoor Sensor 070
- S3 = Storage Sensor 085
- S4 = Source Sensor 071

Essential Control Settings

- 157 DIP = Enable
- 157 Mode = OFF
- 274 Mode = 2

Concept Drawing: This is only a concept drawing, not an engineered drawing. It is not intended to describe a complete system, nor any particular system. It is up to the system designer to determine the necessary components for and configuration of the particular system being designed, including additional equipment, isolation relays (for loads greater than the control's specified output ratings), and any safety devices which in the judgement of the designer are appropriate, in order to properly size, configure and design that system and to ensure compliance with building and safety code requirements.

Notes:

Specifications:

The following are the recommended specifications for the Difference Setpoint Control 157

- The control shall operate the variable speed pump using the powered output on the back of the control when the ΔT rises above the ΔT target
- The control shall transfer heat from a heat source to a storage tank
- The control shall vary the speed of the pump to maintain the target temperature difference (ΔT)
- The control shall display the % output of the variable speed pump in the view menu
- The control shall operate the variable speed pump at 100% output upon start up for an adjustable amount of time
- The control shall operate the variable speed pump above an adjustable minimum pump speed setting
- The control shall operate the variable speed pump at the minimum pump speed for 2 minutes before shutting it off
- The control shall keep the variable speed pump off for a minimum of 5 minutes
- The control shall operate only with the list of manufacturer approved pump models for the variable speed pump
- The control shall operate a second on/off pump with 4 different modes of operation using the powered output on the back of the control
- The control shall operate the second pump as an external heat exchanger pump in mode 1 which turns on whenever the variable speed pump is on
- The control shall have the option of an auxiliary sensor in heat supplement mode 2 and heat dump mode 3
- The control shall operate the second pump as a heat supplement pump in mode 2 which turns on when the storage sensor, or optional auxiliary sensor, falls below the storage minimum target
- The control shall operate the second pump as a heat dump pump in mode 3 which turns on when the storage sensor and source sensor are above their maximum targets, and the optional auxiliary sensor is below the maximum auxiliary target
- The control shall operate the second pump as a booster pump in mode 4 which turns on for the maximum output (minutes) time when the variable speed pump turns on
- The control shall turn off the variable speed pump if the source temperature falls below the adjustable minimum source target (can set to off)
- The control shall turn off the variable speed pump if the storage temperature rises above the adjustable maximum storage target
- The control shall operate the variable speed pump at 100% output if freeze protection is turned on and the source temperature falls below 35°F (2°C) to transfer heat from the storage tank to the source
- The control shall monitor the minimum and maximum temperatures recorded by the source and storage sensors in the view menu
- The control shall calculate the amount of heat transferred from the source to the storage and display the number of BTU's or kWh's in the view menu
- The control shall display the number of pump running hours of the second pump, P2
- The control shall enter a field test when the up button is held for 3 seconds where the variable speed pump is ramped up over 10 seconds then ramped down over 10 seconds and the second pump is turned on for 10 seconds
- The control shall display an error message is the source, storage, or auxiliary sensor has a short or open circuit
- The control shall display an E01 error message if the control was unable to read a piece of information from its EEPROM



tekmar Control Systems Ltd., Canada
tekmar Control Systems, Inc., U.S.A.
Head Office: 5100 Silver Star Road
Vernon, B.C. Canada V1B 3K4
(250) 545-7749 Fax. (250) 545-0650
Web Site: www.tekmarcontrols.com