

Model #SUP033V

1/3 HP Thermoplastic Submersible Sump Pump

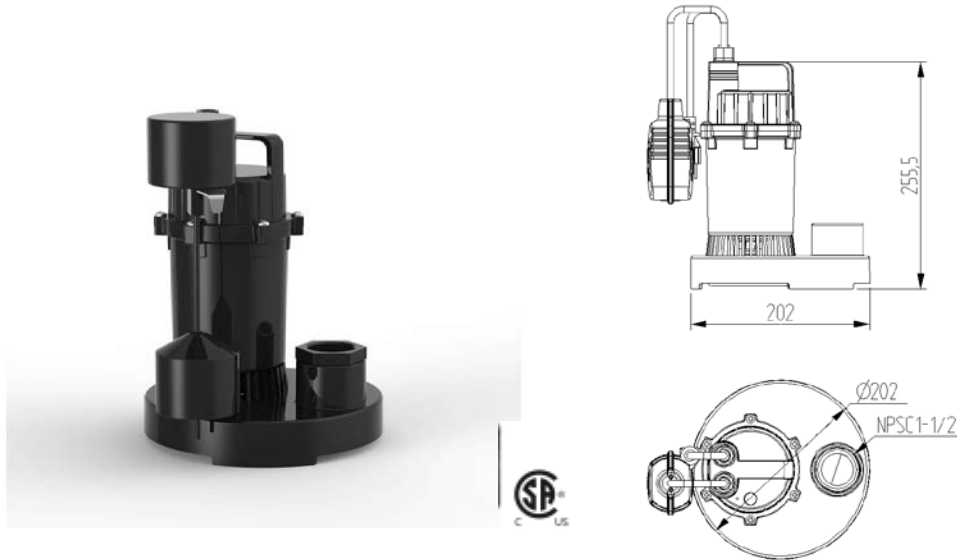

Inlet	Diameter 16.5 inches
Discharge	NPSC1-1/2
Pump Cover	PA66-GF25
Motor Housing	ZL104
Pump Body	PP-TD20
Switch Type	Float switch
Impeller	PP-GF30
Seal Design	Framework oil seal
Seal Material	NBR
Oil Filled Motor	Yes
Power Cord	SJTW 18AWG 10ft
Net Weight	8.7
Gross Weight	9.8
Package Size	9*8.5*11.8
Expected Life Cycle	4000 Hours
Motor Wires	Copper or aluminum
Self-Priming	/
Certification	CSA

Features & Benefits:

- ❖ Corrosion-resistant, reinforced thermoplastic construction.
- ❖ Built-in automatic thermal overload protector.
- ❖ Oil-filled split capacitor motor.
- ❖ Adjustable vertical float switch.
- ❖ Top suction screened design prevents clogs.
- ❖ 10ft power cord.
- ❖ 1 year warranty.

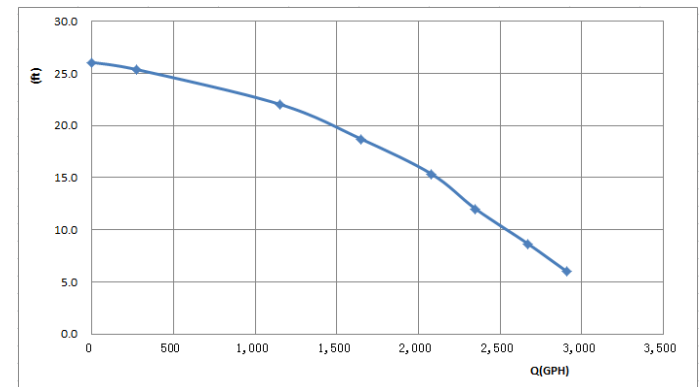

Model	HP	Voltage	AMP	Discharge NPT(In)	GPH of water @ Total Ft. of Head					Max.Head Ft
					5 ft	10 ft	15 ft	20 ft	25 ft	
SUP033V	1/3	115	4.6	1-1/2	2920	2420	1850	950		23