

# TECHNICAL SPECIFICATIONS

## CONNECTIONS



SHOWER



SINK



DISHWASHER



LAUNDRY

## APPLICATION



RESIDENTIAL



COMMERCIAL

# Saniswift® Pro Drain Pump



Example of installation. Follow local plumbing codes for actual install.

The **Saniswift Pro drain pump** is used to pump gray water away from a variety of fixtures in **residential and commercial applications**. The system is able to discharge the waste up to **14 feet vertical and/or 140 feet horizontal**.

- Discharges the waste through either a **1", 1-1/4" or 1-1/2"** rigid pipe. A **non-return valve is included** on the discharge fitting assembly provided with the system.
- Has been designed with a **1-1/2" vent connection** on top of the lid. All plumbing codes require connection to a vent system. Either inlet located on top of the housing can be used for the vent or as an inlet. Please note that the vent system should be a two-way air vent as air needs to freely flow both ways. Note: The use of mechanical vents, air admittance valves or similar devices is not permitted.
- Discharges **gray water from a kitchen sink, shower, dishwasher, washing machine** (indirect connection via laundry sink). The gray water will drain into the **system via three inlets**, two 2" inlets (with built-in check valves) on either side of the housing and one 1-1/2" inlet on top of the enclosure.
- An easy access service panel is located on top of the pump. This **will provide accessibility to the electrical components** such as the capacitor, pressure switch, and electronic board without the need to remove or disconnect the pump. For a full list of parts, please refer to the next page.



CommercialGrade

## PUMPING DISTANCE

14 Ft



140 Ft

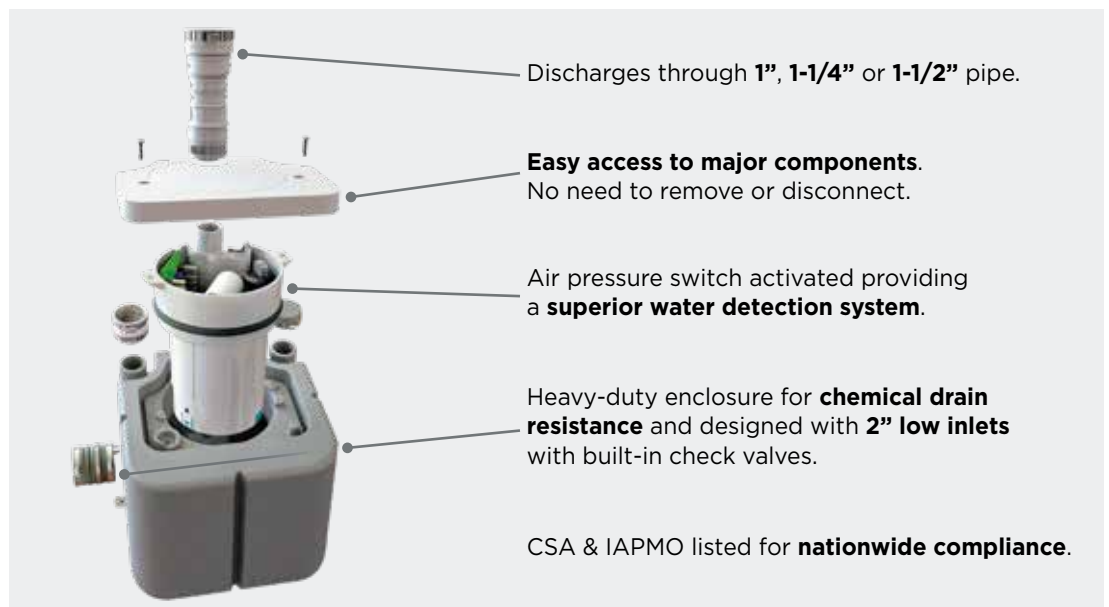

Saniswift Pro • PART N° 022



# TECHNICAL SPECIFICATIONS

PLEASE CALL US TOLL-FREE AT  
 800-571-8191 (US) / 800-363-5874 (CDN)  
 TO PURCHASE PARTS REFERENCED BELOW

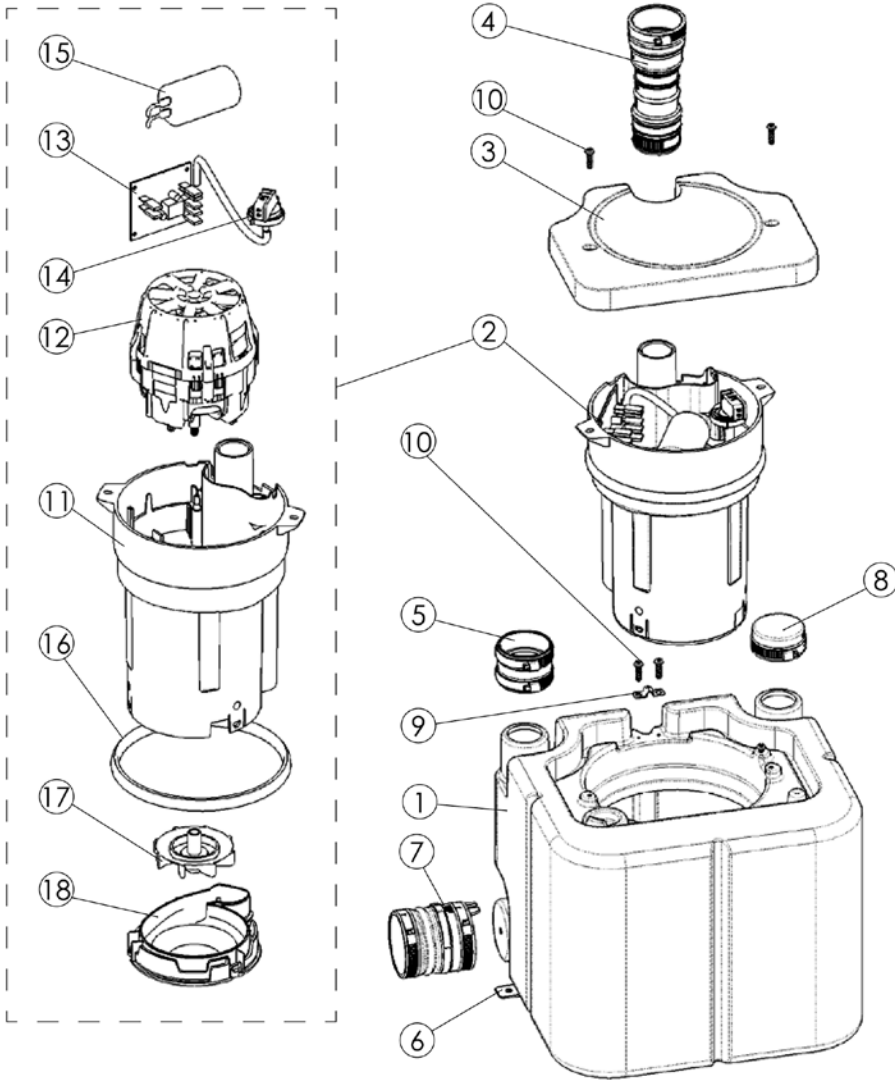

## DIMENSIONAL DRAWINGS

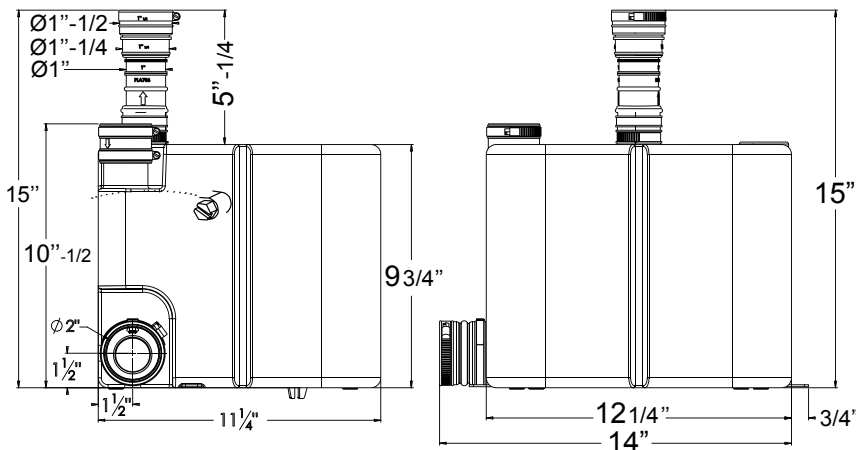

An easy and inexpensive solution for gray water applications!

## TECHNICAL SPECIFICATIONS

**Pump type:**

Drain pump

**Electrical:**

120 V - 60 Hz / 4.5 Amps (Max)\*

**Motor:**

0.3 HP oil-filled thermally protected motor

**Capacitor rating:**

30 microfarad

**Operating Temperature:**

140°F

**Power cord length:**

48 inches

**Noise level:**

≤ 44 dBA (Lp) (measured at 3 ft.)

**Discharge pipe diameter:**

1" - 1-1/2"

**Discharge rate at 14 ft:**

18 GPM

**Discharge rate at 3 ft:**

24 GPM

**Shut-off head:**

25 ft.

**Normal running time:**

3-5 seconds (Short bursts)

**Capacity:**

2.9 gallons / 11 liters

**Inlets:**

2" (sides), 1-1/2" vent (top)

**Method of activation:**

pressure switch/ circuit board

**Shower/bathtub base height:**

6" min

**Weight:**

16 lbs / 7.3 kg

**Certifying agencies:**

CSA (IPC, NSPC), IAPMO (UPC)

**Recommended accessories:**

Descaler

**Connections:**

Sink, shower, washing machine (indirect),  
 dishwasher, laundry sink, etc.

\* Measured using 1" discharge. Information  
 will vary once the discharge size is increased  
 Consult with factory.

