

TECHNICAL SPECIFICATIONS

CONNECTIONS



BOILER



AIR
CONDITIONER



HVAC

APPLICATIONS



RESIDENTIAL



COMMERCIAL

Sanicondens[®] Condensate Pump



Example of installation. Follow local plumbing codes for actual install.

The Sanicondens is a small pump used **to pump condensate from condensing boilers, HVAC systems, water heater systems, etc.** The Sanicondens will pump condensate waste up to **15 feet in height and/or 150 feet away** from a soil stack.

- **Discharges the condensate waste through a 3/8" vinyl tube. A non-return valve is included** on the discharge connection provided with the system.
- The small, powerful pumping unit can be floor or wall mounted. It comes with provisions for **already-to-wire connection to an external overflow switch** that will shut down the appliance or alert the consumer in the event of overflow. It also includes all necessary hardware for ease of installation; **20 Ft of vinyl tubing, inlet adapter, discharge adapter.**
- Discharges **condensate from a condensing boiler or other condensate producing fixtures.**

The condensate will drain into the system via **two 1" inlets located on top of the enclosure.**



PUMPING DISTANCE

15 Ft



150 Ft

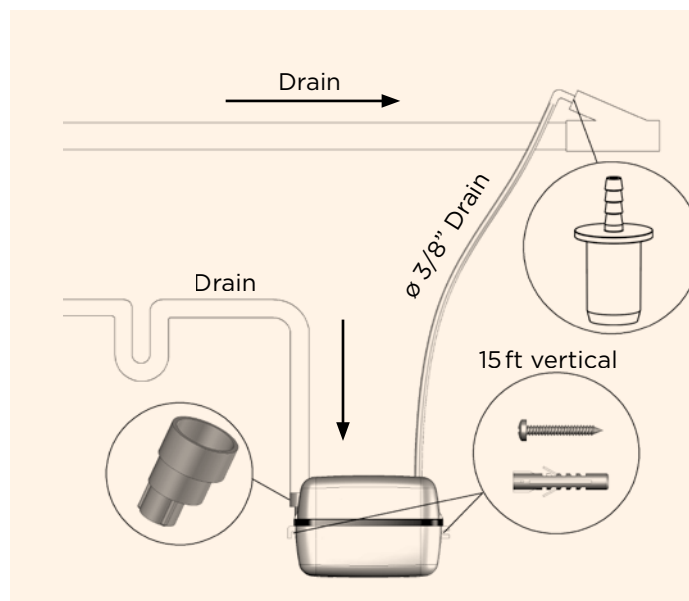

AN EASY SOLUTION TO PUMP CONDENSATE AWAY FROM CONDENSING BOILERS AND AIR CONDITIONERS

One of the **most powerful and quiet condensate pumps** on the market with features that no competitor can match.

The two-quart capacity condensate pump comes equipped with **all the necessary hardware for easy installation.** It can be installed on top of a flat surface or mounted on a wall.



TECHNICAL SPECIFICATIONS

PLEASE CALL US TOLL-FREE AT
800-571-8191 (US) / 800-363-5874 (CDN)
 TO PURCHASE PARTS REFERENCED BELOW

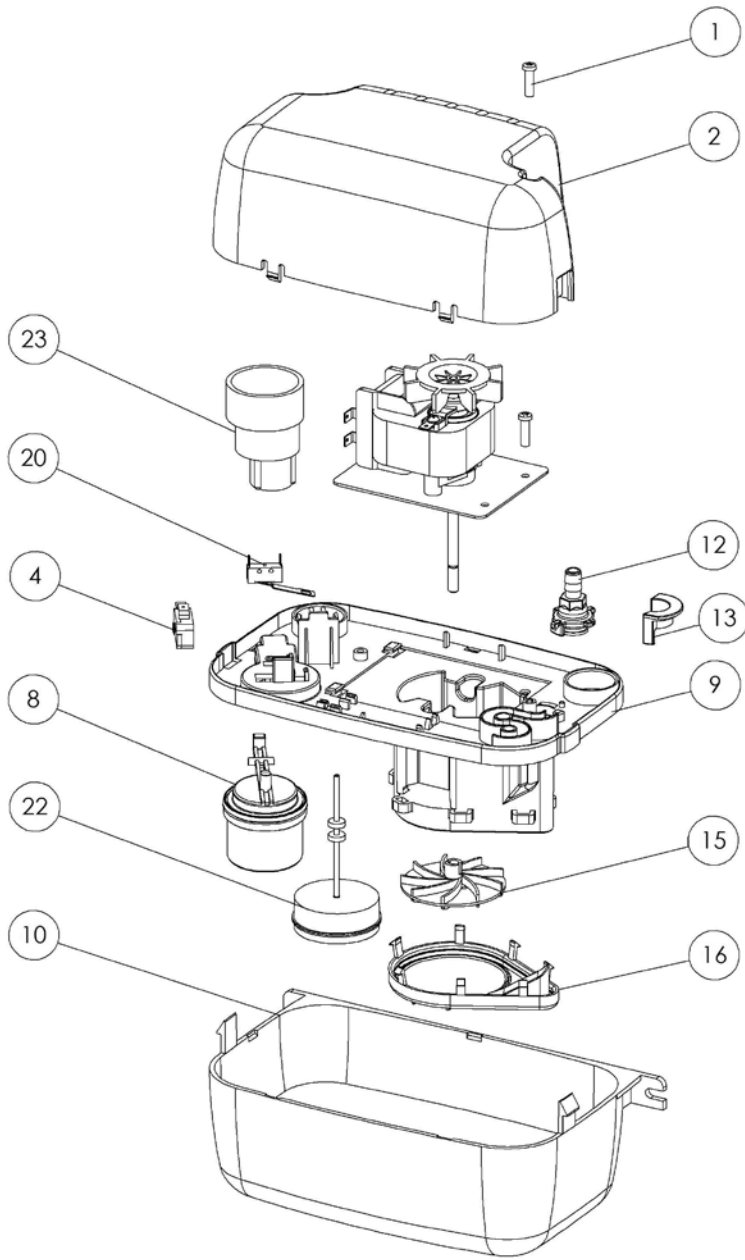

DIMENSIONAL DRAWINGS

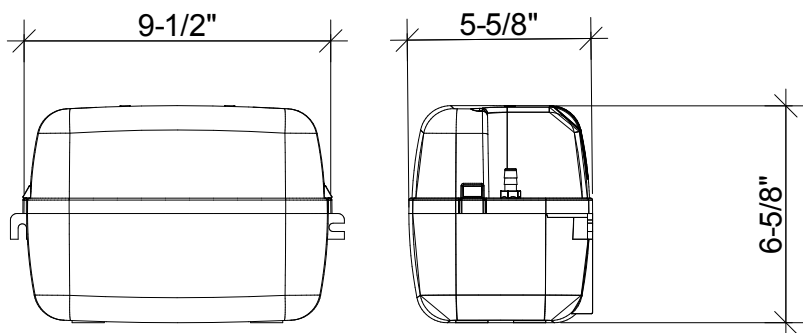

Pump away condensate from any HVAC application!

TECHNICAL SPECIFICATIONS

Pump type:

Condensate Pump

Electrical:

120 V - 60 Hz / 1.5 Amps (Max)

Motor:

1/30 HP oil-filled thermally protected motor

Operating Temperature:

160°F Max

Power cord length:

60 inches

Noise level:

≤ 44 dBA (Lp) (measured at 3 ft.)

Discharge pipe diameter:

3/8"

Discharge rate at 15 ft:

30 GPH

Discharge rate at 3 ft:

86 GPH

Normal running time:

3-5 seconds (Short bursts)

Capacity:

0.5 gallons / 1.9 liters

Inlets:

1" (top)

Method of activation:

Float/microswitch

Weight:

7 lbs / 3.1 kg

Certifying agencies:

CSA (IPC, NSPC)

Connections:

Condensing boiler, HVAC systems,
 air conditioners

