



HOMETECHTM
Portable Technologies



1 Applewood Crescent, Unit 8, Vaughan, ON L4K 4K1

Ph.: 1-888-538-0082

Email: pumps@hena.ca

www.leogroup.cn

Rev. 06.01.2023

Model #LSC-252PL

1/3 HP Submersible Utility Pump

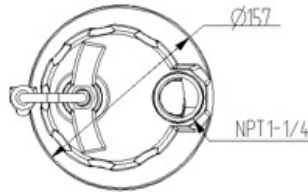
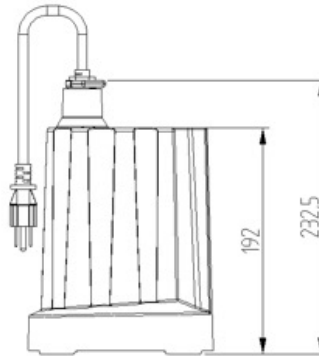

Features & Benefits:

- ❖ Continuous duty and easy access handle for portability.
- ❖ Corrosion-resistant, reinforced thermoplastic construction.
- ❖ Bottom suction design filters debris and removes water down to 1/4" from surface.
- ❖ Built-in automatic thermal overload protector motor.
- ❖ 3/4" NPT discharge, 1 1/4" adapter included.
- ❖ Top discharge design.
- ❖ 10ft power cord.
- ❖ 1 year warranty.

| | |
|---------------------|----------------------|
| Inlet | Diameter 14.4 inches |
| Discharge | NH 3/4 |
| Pump Cover | PA66-GF25 |
| Motor Housing | ZL104+DMC |
| Pump Body | PP-GF30 |
| Switch Type | / |
| Impeller | PA6-GF25 |
| Seal Design | Framework oil seal |
| Seal Material | NBR |
| Oil Filled Motor | Yes |
| Power Cord | SJTW 18AWG 10ft |
| Net Weight (lbs) | 8.2 |
| Gross Weight (lbs) | 9.5 |
| Package Size(in) | 7.9*7*11 |
| Expected Life Cycle | 4000 Hours |
| Motor Wires | Aluminium wire |
| Self-Priming | / |
| Certification | UL |

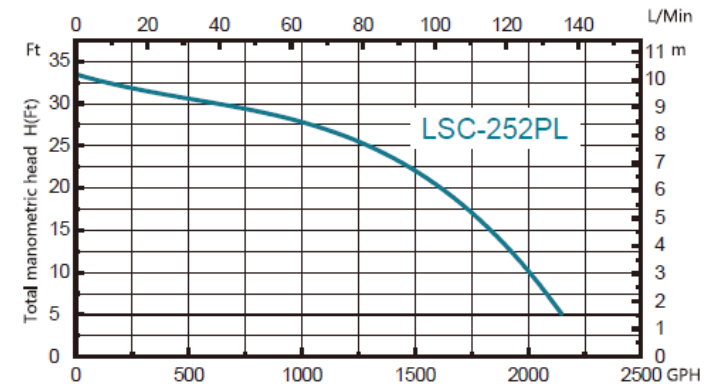

| Model | HP | Voltage | AMP | Discharge NPT(In) | GPH of water @ Total Ft. of Head | | | | | Max.Head Ft |
|-----------|-----|---------|-----|-------------------|----------------------------------|-------|-------|-------|-------|-------------|
| | | | | | 5 ft | 10 ft | 15 ft | 20 ft | 25 ft | |
| LSC-252PL | 1/3 | 115 | 4 | 1-1/4 | 2110 | 2000 | 1850 | 1650 | 1300 | 33.5 |

Model #LSC-256PEL

1/3 HP Submersible Automatic Utility Pump

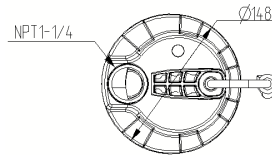
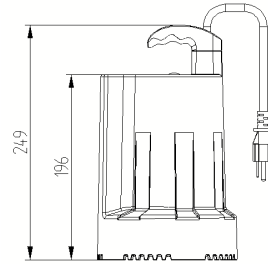

| | |
|---------------------|----------------------|
| Inlet | Diameter 14.4 inches |
| Discharge | NH3/4 |
| Pump Cover | PA66-GF25 |
| Motor Housing | ZL104+DMC |
| Pump Body | PP-GF30 |
| Switch Type | / |
| Impeller | PA6-GF25 |
| Seal Design | Framework oil seal |
| Seal Material | NBR |
| Oil Filled Motor | Yes |
| Power Cord | SJTW 18AWG 10ft |
| Net Weight (lbs) | 9.2 |
| Gross Weight (lbs) | 10.2 |
| Package Size(in) | 8.0*7.2*12.4 |
| Expected Life Cycle | 4000 Hours |
| Motor Wires | Aluminium wire |
| Self-Priming | / |
| Certification | UL |

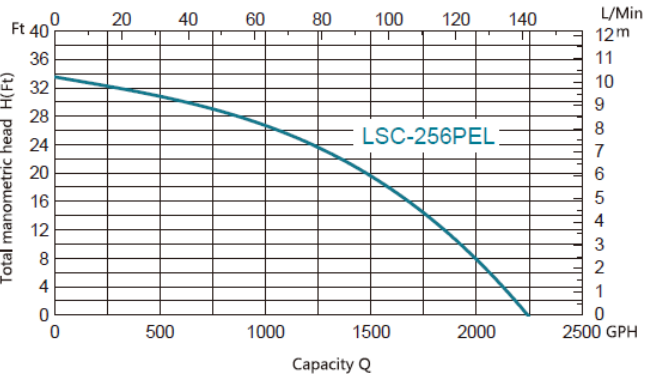

- Features & Benefits:**
- ❖ Automatically turns on when 1 ½" of water is detected; turns off when water level fall below ¼".
 - ❖ Corrosion-resistant, reinforced thermoplastic construction.
 - ❖ Bottom suction design filters debris and removes water down to ¼" from surface.
 - ❖ Permanent split capacitor motor and built-in automatic thermal overload protector.
 - ❖ 1" NPT discharge, ¾" adapter included.
 - ❖ 10ft power cord.
 - ❖ 2-year warranty.

| Model | HP | Voltage | AMP | Discharge NPT(In) | GPH of water @ Total Ft. of Head | | | | | Max.Head Ft |
|-----------|-----|---------|-----|-------------------|----------------------------------|-------|-------|-------|-------|-------------|
| | | | | | 5 ft | 10 ft | 15 ft | 20 ft | 25 ft | |
| LSC256PEL | 1/3 | 115 | 4 | 1 | 2110 | 1900 | 1700 | 1490 | 1110 | 33.5 |

LEO Model #LKS-200P

1/6 HP Submersible Battery Utility Pump



Features & Benefits:

- Excellent backup during power outage or when no power source is available.
- Waterproof switch provides either AC or DC power supply.
- Overload protection and Dry-running protection.
- Keeps working for 30 mins from single Charge
- Patented Design.
- Voltage: 18V
- Input Power : 1/6HP
- MAX Flow: 1450GPH

| | |
|--------------------|------------------|
| Inlet | / |
| Discharge | 1 in NPT |
| Pump Cover | PA66-GF25 |
| Motor Housing | / |
| Pump Body | PP-GF30 |
| Switch Type | push-button type |
| Impeller | PPO_GF30 |
| Seal Design | Oil seal |
| Seal Material | / |
| Oil Filled Motor | lithium battery |
| Power Cord | No cord |
| Net Weight (lbs) | 5.28 lbs |
| Gross Weight (lbs) | 6.0 lbs |
| Package Size (in) | 9.1*5.8*9.1 |
| Motor Wires | / |
| Self-Priming | yes |
| Certification | UL |

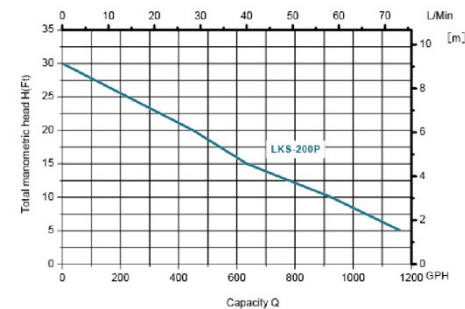

| Model | HP | Voltage | AMP | Discharge NPT(In) | GPH of water @ Total Ft. of Head | | | | | Max.Head Ft |
|----------|-----|---------|-----|-------------------|----------------------------------|-------|-------|-------|-------|-------------|
| | | | | | 5 ft | 10 ft | 15 ft | 20 ft | 25 ft | |
| LKS-200P | 1/6 | 18V DC | 10A | 1 | 1163 | 925 | 635 | 450 | 230 | 30 |

Model #PM050B

1/2HP Portable Cast Iron Transfer Pump

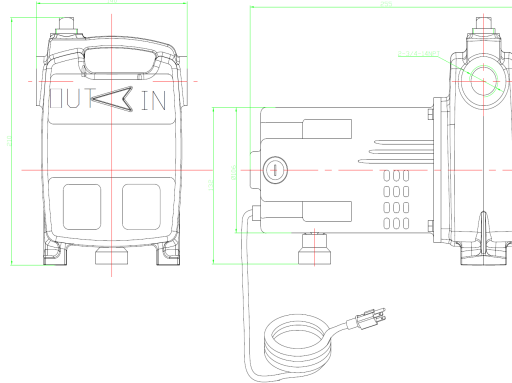

| | |
|---------------------|-------------------------------------|
| Inlet | 3/4 inNPT |
| Discharge | 3/4 inNPT |
| Pump Cover | / |
| Motor Housing | PC+30%GF |
| Pump Body | HT200 |
| Switch Type | / |
| Impeller | PPO |
| Seal Design | O-ring |
| Seal Material | Silicone rubber |
| Oil Filled Motor | No |
| Power Cord | SJT 221F VW-1 16AWG×3C FT1 7.9ft |
| Net Weight (lbs) | 14.6 |
| Gross Weight (lbs) | 16 |
| Package Size | 11.614in*6.693in*8.661in |
| Expected Life Cycle | 2000 Hours |
| Motor Wires | Copper |
| Self-Priming | No |
| Certification | CSA |

Features & Benefits:

- ❖ Convenient carrying handle for easy transport
- ❖ Durable cast iron volute
- ❖ Built-in automatic thermal overload protector
- ❖ 3/4" brass adapters connect to standard garden hose
- ❖ Water suction attachment included
- ❖ 2-year warranty

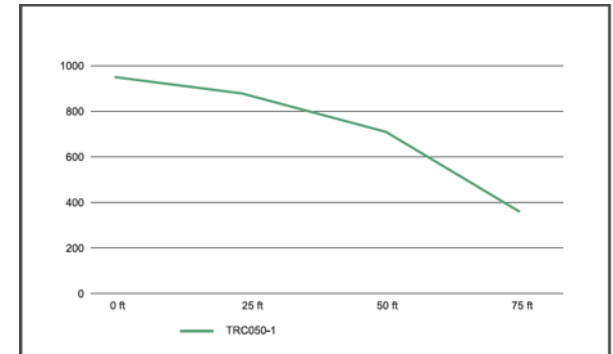

| Model | HP | Voltage | AMP | Discharge NPT(In) | GPH of water @ Total Ft. of Head | | | | Max.Head Ft |
|---------------|-----|---------|------|-------------------|----------------------------------|-------|-------|-------|-------------|
| | | | | | 0 ft | 25 ft | 50 ft | 75 ft | |
| PM050B | 1/2 | 115 | 0.8A | 3/4" | 950 | 897 | 739 | 380 | 80 |

Model #PM001C

Portable Transfer Pump

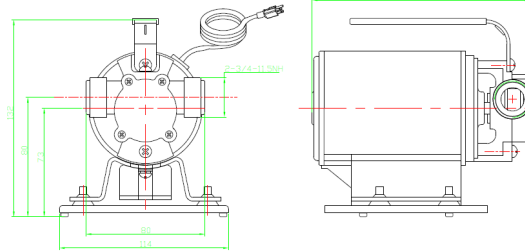

| | |
|--------------------|----------------------------------|
| Inlet | 3/4 inNH |
| Discharge | 3/4 inNH |
| Pump Cover | Stainless steel1Cr13-3Cr13 |
| Motor Housing | Mild steel10# |
| Pump Body | Brass HPb59-1 |
| Switch Type | / |
| Impeller | Synthetic rubber EPDM |
| Seal Design | O-ring |
| Seal Material | Silicone rubber |
| Oil Filled Motor | no |
| Power Cord | SJT 221F VW-1 18AWG×3C FT1 5.9ft |
| Net Weight (lbs) | 4.7 |
| Gross Weight (lbs) | 7 |
| Package Size | 9.449in*9.449in*5.906in |
| Motor Wires | Copper |
| Self-Priming | No |
| Certification | CSA |

Features & Benefits:

- ❖ Built-in automatic thermal overload protection.
- ❖ Convenient carrying handle for easy transport.
- ❖ 3/4" NPT discharge.
- ❖ Garden hose included.
- ❖ 6ft power cord.
- ❖ 1 year warranty.

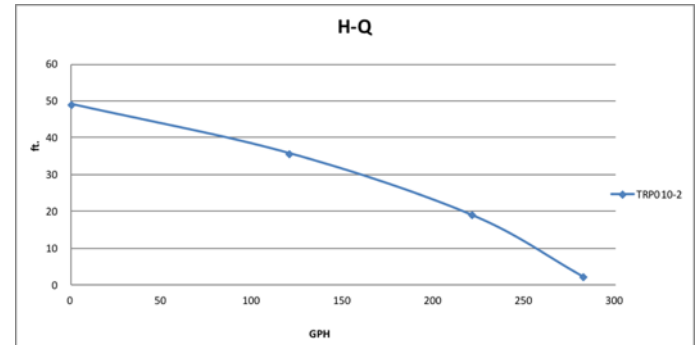

| Model | HP | Voltage | AMP | Discharge NPT(In) | GPH of water @ Total Ft. of Head | | | | | Max.Head Ft |
|---------------|------|---------|-----|-------------------|----------------------------------|-------|-------|-------|-------|-------------|
| | | | | | 5 ft | 15 ft | 25 ft | 35 ft | 45 ft | |
| PM001C | 1/10 | 115 | 1.8 | 3/4 | 365 | 310 | 259 | 160 | 27 | 46 |

Model #LSD-252PLT

1/3 HP Thermoplastic Submersible Sump Pump

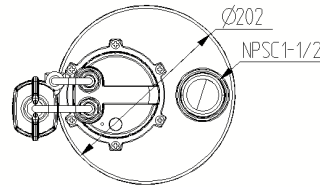
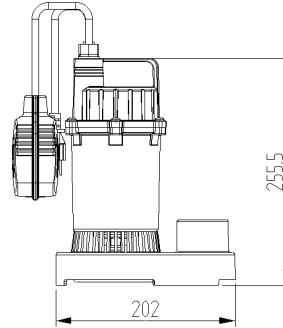

Features & Benefits:

- ❖ Corrosion-resistant, reinforced thermoplastic construction.
- ❖ Built-in automatic thermal overload protector.
- ❖ Oil-filled split capacitor motor.
- ❖ Adjustable tethered float switch.
- ❖ Top suction screened design prevents clogs.
- ❖ 10ft power cord.
- ❖ 1 year warranty.

| | |
|---------------------|----------------------|
| Inlet | Diameter 16.5 inches |
| Discharge | NPSC1-1/2 |
| Pump Cover | PA66-GF25 |
| Motor Housing | ZL104 |
| Pump Body | PP-TD20 |
| Switch Type | Float switch |
| Impeller | PP-GF30 |
| Seal Design | Framework oil seal |
| Seal Material | NBR |
| Oil Filled Motor | Yes |
| Power Cord | SJTW 18AWG 10ft |
| Net Weight | 8.7 |
| Gross Weight | 9.8 |
| Package Size | 9*8.5*11.8 |
| Expected Life Cycle | 4000 Hours |
| Motor Wires | Aluminum |
| Self-Priming | / |
| Certification | UL |

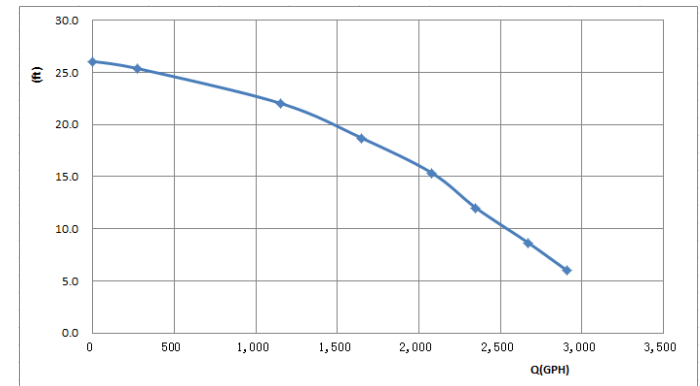

| Model | HP | Voltage | AMP | Discharge NPT(In) | GPH of water @ Total Ft. of Head | | | | | Max.Head Ft |
|-------------------|-----|---------|-----|-------------------|----------------------------------|-------|-------|-------|-------|-------------|
| | | | | | 5 ft | 10 ft | 15 ft | 20 ft | 25 ft | |
| LSD-252PLT | 1/3 | 115 | 4.6 | 1-1/2 | 2560 | 2300 | 1900 | 1000 | 100 | 23 |

Model #LSD-252PLV

1/3 HP Thermoplastic Submersible Sump Pump

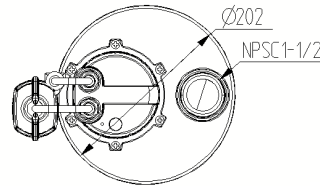
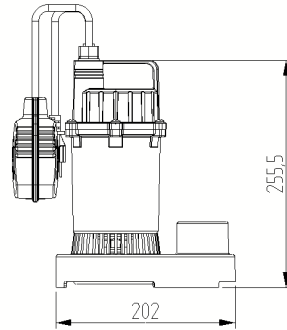

| | |
|---------------------|----------------------|
| Inlet | Diameter 16.5 inches |
| Discharge | NPSC1-1/2 |
| Pump Cover | PA66-GF25 |
| Motor Housing | ZL104 |
| Pump Body | PP-TD20 |
| Switch Type | Float switch |
| Impeller | PP-GF30 |
| Seal Design | Framework oil seal |
| Seal Material | NBR |
| Oil Filled Motor | Yes |
| Power Cord | SJTW 18AWG 10ft |
| Net Weight (lbs) | 8.7 |
| Gross Weight (lbs) | 9.8 |
| Package Size | 9.1*8.5*11.8 |
| Expected Life Cycle | 4000 Hours |
| Motor Wires | Aluminum |
| Self-Priming | / |
| Certification | UL |

Features & Benefits:

- ❖ Corrosion-resistant, reinforced thermoplastic construction.
- ❖ Built-in automatic thermal overload protector.
- ❖ Oil-filled split capacitor motor.
- ❖ Adjustable vertical float switch.
- ❖ Top suction screened design prevents clogs.
- ❖ 10ft power cord.
- ❖ 1 year warranty.

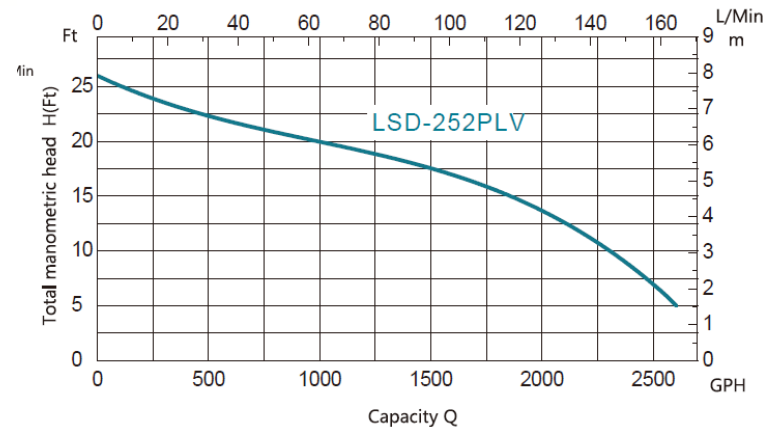

| Model | HP | Voltage | AMP | Discharge NPT(In) | GPH of water @ Total Ft. of Head | | | | | Max.Head Ft |
|-------------------|-----|---------|-----|-------------------|----------------------------------|-------|-------|-------|-------|-------------|
| | | | | | 5 ft | 10 ft | 15 ft | 20 ft | 25 ft | |
| LSD-253PLV | 1/3 | 115 | 4.6 | 1-1/2 | 2560 | 2300 | 1900 | 1000 | 100 | 26 |

Model #LSD-253SV

1/3 HP Stainless Steel Housing-Cast Iron Base Sump Pump

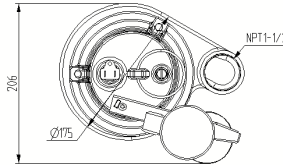
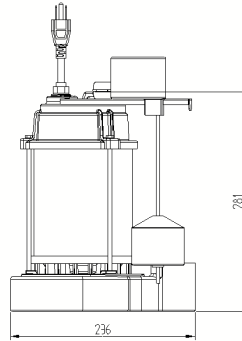

| | |
|---------------------|--------------------|
| Inlet | Diameter 18 inches |
| Discharge | NPT1/1/2 |
| Pump Cover | HT200 |
| Motor Housing | 304 |
| Pump Body | HT200 |
| Switch Type | Vertical |
| Impeller | PA6-GF40 |
| Seal Design | Framework oil seal |
| Seal Material | NBR |
| Oil Filled Motor | YES |
| Power Cord | SJTW 18AWG 8ft |
| Net Weight (lbs) | 21.4 |
| Gross Weight (lbs) | 23.6 |
| Package Size(in) | 11×8.3×15.2 |
| Expected Life Cycle | 4000 Hours |
| Motor Wires | Copper |
| Self-Priming | / |
| Certification | CSA |

Features & Benefits:

- ❖ Stainless steel motor shell with durable cast iron volute.
- ❖ Oil-filled permanent split capacitor motor.
- ❖ Built-in automatic thermal overload protector.
- ❖ Vertical float switch for automatic operation.
- ❖ 1 ½ " discharge.
- ❖ Sturdy pump base prevent clogs and prevents pump from moving around in the pit.
- ❖ 8ft power cord.
- ❖ 3-year warranty.

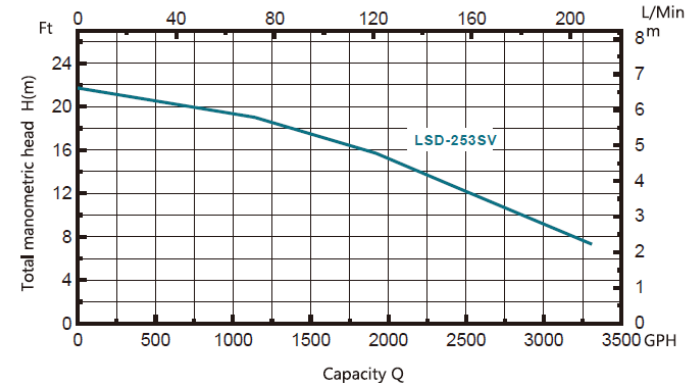

| Model | HP | Voltage | AMP | Discharge NPT(In) | GPH of water @ Total Ft. of Head | | | | | Max.Head Ft |
|------------------|-----|---------|-----|-------------------|----------------------------------|-------|-------|-------|-------|-------------|
| | | | | | 5 ft | 10 ft | 15 ft | 20 ft | 25 ft | |
| LSD-253SV | 1/3 | 115 | 4.5 | 1-1/2 | 3300 | 2800 | 2000 | 750 | | 22 |

Model #LSD-373SV

1/2 HP Stainless Steel Housing- Cast Iron Base Sump Pump

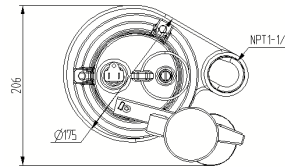
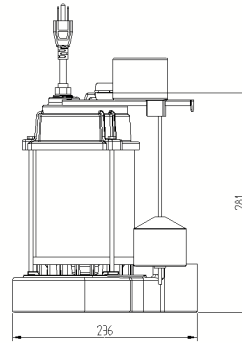

| | |
|---------------------|--------------------|
| Inlet | Diameter 18 inches |
| Discharge | NPT1/1/2 |
| Pump Cover | HT200 |
| Motor Housing | 304 |
| Pump Body | HT200 |
| Switch Type | SJE VMII vertical |
| Impeller | PA6-GF40 |
| Seal Design | Framework oil seal |
| Seal Material | NBR |
| Oil Filled Motor | Yes |
| Power Cord | SJTW 18AWG 8ft |
| Net Weight (lbs) | 25.4 |
| Gross Weight (lbs) | 27.4 |
| Package Size | 11*8.3*15.2 |
| Expected Life Cycle | 4000 Hours |
| Motor Wires | Copper |
| Self-Priming | / |
| Certification | CSA |

Features & Benefits:

- ❖ Stainless steel motor shell with durable cast iron volute.
- ❖ Oil-filled permanent split capacitor motor.
- ❖ Built-in automatic thermal overload protector.
- ❖ Vertical float switch for automatic operation.
- ❖ 1 1/2 " discharge.
- ❖ Sturdy pump base prevent clogs and prevents pump from moving around in the pit.
- ❖ 8ft power cord.
- ❖ 3-year warranty.

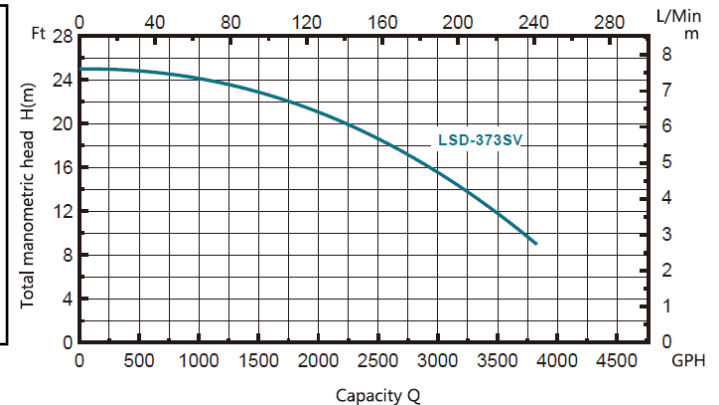

| Model | HP | Voltage | AMP | Discharge NPT(In) | GPH of water @ Total Ft. of Head | | | | | Max.Head Ft |
|------------------|-----|---------|-----|----------------------|----------------------------------|-------|-------|-------|-------|-------------|
| | | | | | 5 ft | 10 ft | 15 ft | 20 ft | 25 ft | |
| LSD-373SV | 1/2 | 115 | 5 | 1-1/2 | 3830 | 3750 | 3050 | 2250 | | 24.6 |

Model #USC-37WE

½ HP Cast Iron Effluent Pump

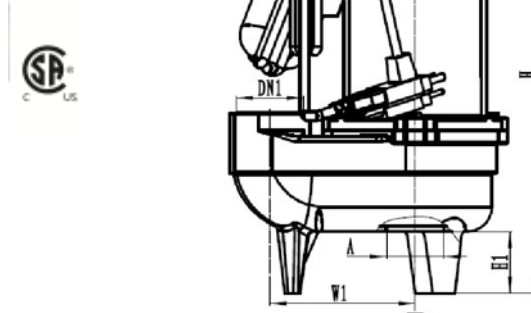

Features & Benefits:

- ❖ Durable cast iron construction.
- ❖ Heavy-duty cast-iron volute and nylon impeller.
- ❖ Built-in automatic thermal overload protector motor.
- ❖ Adjustable piggyback float switch for automatic operation.
- ❖ Application up to 3/4" diameter solids.
- ❖ 2" NPT discharge.
- ❖ 10ft power cord.
- ❖ 2-year warranty.

| | |
|---------------------|----------------------|
| Inlet | 3/4inch |
| Discharge | NPT2 |
| Pump Cover | HT200 |
| Motor Housing | 08F |
| Pump Body | HT200 |
| Switch Type | Float switch |
| Impeller | PA6-GF25 |
| Seal Design | Mechanical seal |
| Seal Material | Graphite & Ceramic |
| Oil Filled Motor | Yes |
| Power Cord | SJTW3*18AWG |
| Net Weight (lbs) | 29 |
| Gross Weight (lbs) | 30.6 |
| Package Size | 11.2*7.5*17.1 |
| Expected Life Cycle | ON-OFF 300,000 Times |
| Motor Wires | Copper |
| Self-Priming | No |
| Certification | CSA |

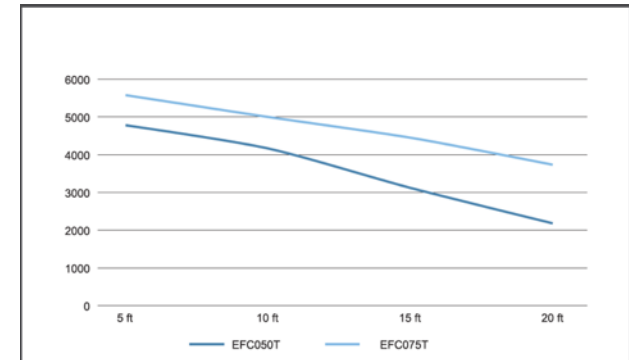

| Model | HP | Voltage | AMP | Discharge NPT(In) | GPH of water @ Total Ft. of Head | | | | | Max.Head Ft |
|-----------------|-----|---------|-----|-------------------|----------------------------------|-------|-------|-------|-------|-------------|
| | | | | | 5 ft | 10 ft | 15 ft | 20 ft | 25 ft | |
| USC-37WE | 1/2 | 120 | 7.8 | 2 | 4800 | 4050 | 3200 | 2200 | 1379 | 27 |

Model #USC-37WE-20

½ HP Cast Iron Effluent Pump

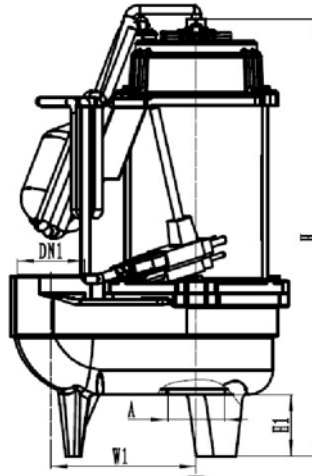

Features & Benefits:

- ❖ Durable cast iron construction.
- ❖ Heavy-duty cast-iron volute and nylon impeller.
- ❖ Built-in automatic thermal overload protector motor.
- ❖ Adjustable tethered or piggyback float switch for automatic operation.
- ❖ Application up to 3/4" diameter solids.
- ❖ 2" NPT discharge.
- ❖ 20ft power cord.
- ❖ 2-year warranty.

| | |
|---------------------|----------------------|
| Inlet | 3/4inch |
| Discharge | NPT2 |
| Pump Cover | HT200 |
| Motor Housing | 08F |
| Pump Body | HT200 |
| Switch Type | Float switch |
| Impeller | PA6-GF25 |
| Seal Design | Mechanical seal |
| Seal Material | Graphite & Ceramic |
| Oil Filled Motor | Yes |
| Power Cord | SJTW3*18AWG |
| Net Weight (lbs) | 32 |
| Gross Weight (lbs) | 34 |
| Package Size | 11.2*7.5*17.1 |
| Expected Life Cycle | ON-OFF 300,000 Times |
| Motor Wires | Copper |
| Self-Priming | No |
| Certification | CSA |

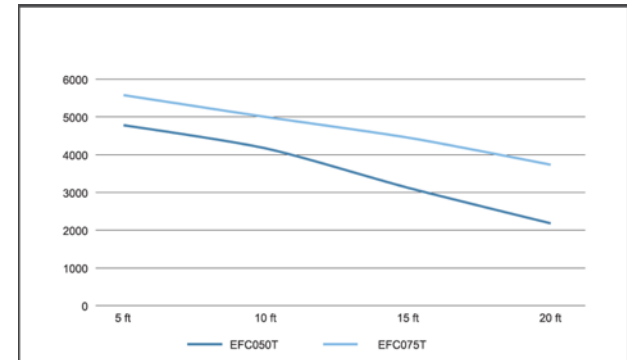

| Model | HP | Voltage | AMP | Discharge NPT(In) | GPH of water @ Total Ft. of Head | | | | | Max.Head Ft |
|--------------------|-----|---------|-----|-------------------|----------------------------------|-------|-------|-------|-------|-------------|
| | | | | | 5 ft | 10 ft | 15 ft | 20 ft | 25 ft | |
| USC-37WE-20 | 1/2 | 120 | 7.8 | 2 | 4800 | 4050 | 3200 | 2200 | 1379 | 27 |

Model #USC-56WE

3/4 HP Cast Iron Effluent Pump

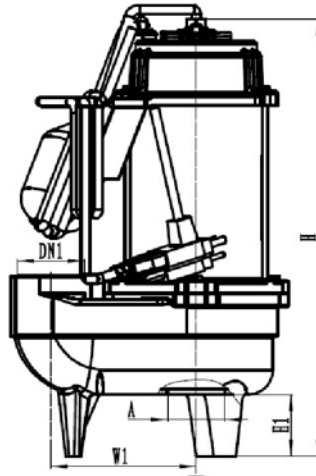

Features & Benefits:

- ❖ Durable cast iron construction.
- ❖ Heavy duty cast iron volute and nylon impeller.
- ❖ Built-in automatic thermal overload protector motor.
- ❖ Adjustable tethered or piggyback float switch for automatic operation.
- ❖ Application up to 3/4" diameter solids.
- ❖ 2" NPT discharge.
- ❖ 10ft power cord.
- ❖ 2-year warranty.

| | |
|---------------------|----------------------|
| Inlet | 3/4inch |
| Discharge | NPT2 |
| Pump Cover | HT200 |
| Motor Housing | 08F |
| Pump Body | HT200 |
| Switch Type | Float switch |
| Impeller | PA6-GF25 |
| Seal Design | Mechanical seal |
| Seal Material | Graphite & Ceramic |
| Oil Filled Motor | Yes |
| Power Cord | SJTW3*18AWG |
| Net Weight (lbs) | 31 |
| Gross Weight (lbs) | 33 |
| Package Size | 11.2*7.5*17.1 |
| Expected Life Cycle | ON-OFF 300,000 Times |
| Motor Wires | Copper |
| Self-Priming | No |
| Certification | CSA |

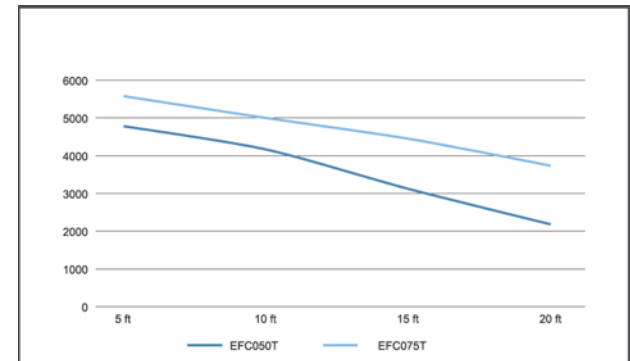

| Model | HP | Voltage | AMP | Discharge NPT(In) | GPH of water @ Total Ft. of Head | | | | | Max.Head Ft |
|-----------------|------------|---------|-----|-------------------|----------------------------------|-------|-------|-------|-------|-------------|
| | | | | | 5 ft | 10 ft | 15 ft | 20 ft | 25 ft | |
| USC-56WE | 3/4 | 120 | 10A | 2 | 5600 | 5000 | 4400 | 3750 | 2498 | 37 |

Model #USC-56WE-20

3/4 HP Cast Iron Effluent Pump

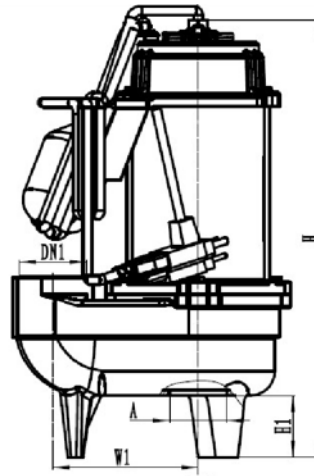

| | |
|---------------------|----------------------|
| Inlet | 3/4inch |
| Discharge | NPT2 |
| Pump Cover | HT200 |
| Motor Housing | 08F |
| Pump Body | HT200 |
| Switch Type | Float switch |
| Impeller | PA6-GF25 |
| Seal Design | Mechanical seal |
| Seal Material | Graphite & Ceramic |
| Oil Filled Motor | Yes |
| Power Cord | SJTW3*18AWG |
| Net Weight (lbs) | 34 |
| Gross Weight (lbs) | 36 |
| Package Size | 11.2*7.5*17.1 |
| Expected Life Cycle | ON-OFF 300,000 Times |
| Motor Wires | Copper |
| Self-Priming | No |
| Certification | CSA |

Features & Benefits:

- ❖ Durable cast iron construction.
- ❖ Heavy-duty cast-iron volute and nylon impeller.
- ❖ Built-in automatic thermal overload protector motor.
- ❖ Adjustable tethered or piggyback float switch for automatic operation.
- ❖ Application up to 3/4" diameter solids.
- ❖ 2" NPT discharge.
- ❖ 20ft power cord.
- ❖ 2-year warranty.

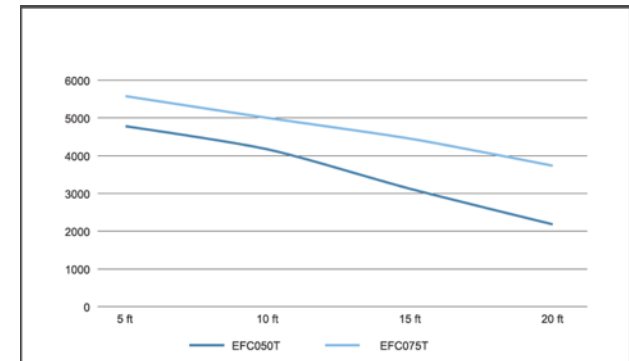

| Model | HP | Voltage | AMP | Discharge NPT(In) | GPH of water @ Total Ft. of Head | | | | | Max.Head Ft |
|--------------------|------------|---------|-----|-------------------|----------------------------------|-------|-------|-------|-------|-------------|
| | | | | | 5 ft | 10 ft | 15 ft | 20 ft | 25 ft | |
| USC-56WE-20 | 3/4 | 120 | 10A | 2 | 5600 | 5000 | 4400 | 3750 | 2498 | 37 |

Model #USC37W-1

½ HP Cast Iron Sewage Pump

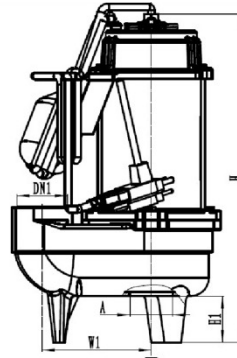

Features & Benefits:

- ❖ Durable cast iron construction.
- ❖ Heavy-duty cast-iron volute and nylon impeller.
- ❖ Built-in automatic thermal overload protector motor.
- ❖ Adjustable tethered or piggyback float switch for automatic operation.
- ❖ Application up to 2" diameter solids.
- ❖ 2" NPT discharge.
- ❖ 10ft power cord.
- ❖ 2-year warranty.

| | |
|---------------------|---------------------------------------|
| Inlet | 2 inch |
| Discharge | NPT2 |
| Pump Cover | HT200 |
| Motor Housing | 08F |
| Pump Body | HT200 |
| Switch Type | Float switch |
| Impeller | PA6-GF25 |
| Seal Design | Mechanical seal |
| Seal Material | Carborundum & Carborundum |
| Oil Filled Motor | Yes |
| Power Cord | SJTW3*18AWG |
| Net Weight (lbs) | 32 lbs |
| Gross Weight (lbs) | 34.8 lbs |
| Package Size | 11.2*7.5*17.6 inches |
| Expected Life Cycle | ON 10 Sec. OFF 30 Sec. 100,000 cycles |
| Motor Wires | Copper |
| Self-Priming | No |
| Certification | CSA |

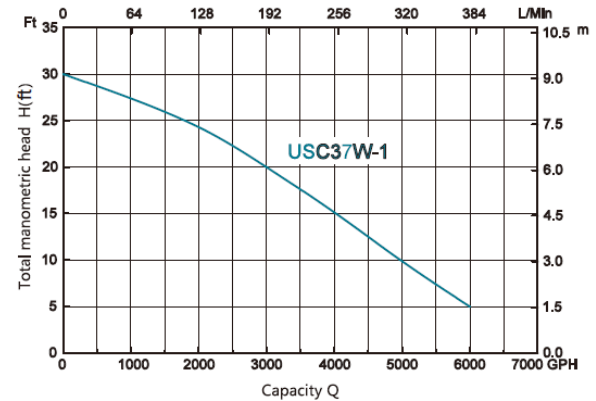

| Model | HP | Voltage | AMP | Discharge NPT(In) | GPH of water @ Total Ft. of Head | | | | | Max.Head Ft |
|-----------------|-----|---------|-----|-------------------|----------------------------------|-------|-------|-------|-------|-------------|
| | | | | | 5 ft | 10 ft | 15 ft | 20 ft | 25 ft | |
| USC37W-1 | 1/2 | 120 | 9.5 | 2 | 6000 | 4950 | 4050 | 3000 | 1950 | 30 |

Model #USC37W-1-20

½ HP Cast Iron Sewage Pump

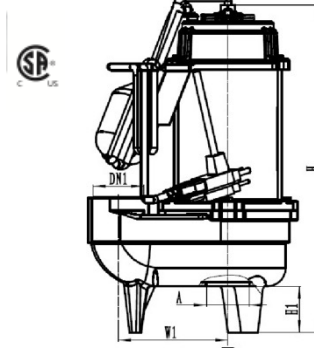

Features & Benefits:

- ❖ Durable cast iron construction.
- ❖ Heavy-duty cast-iron volute and nylon impeller.
- ❖ Built-in automatic thermal overload protector motor.
- ❖ Adjustable tethered or piggyback float switch for automatic operation.
- ❖ Application up to 2" diameter solids.
- ❖ 2" NPT discharge.
- ❖ 20ft power cord.
- ❖ 2-year warranty.

| | |
|---------------------|---------------------------------------|
| Inlet | 2 inch |
| Discharge | NPT2 |
| Pump Cover | HT200 |
| Motor Housing | 08F |
| Pump Body | HT200 |
| Switch Type | Float switch |
| Impeller | PA6-GF25 |
| Seal Design | Mechanical seal |
| Seal Material | Carborundum & Carborundum |
| Oil Filled Motor | Yes |
| Power Cord | SJTW3*18AWG |
| Net Weight (lbs) | 36 lbs |
| Gross Weight(lbs) | 38 lbs |
| Package Size | 11.2*7.5*17.6 inches |
| Expected Life Cycle | ON 10 Sec. OFF 30 Sec. 100,000 cycles |
| Motor Wires | Copper |
| Self-Priming | No |
| Certification | CSA |

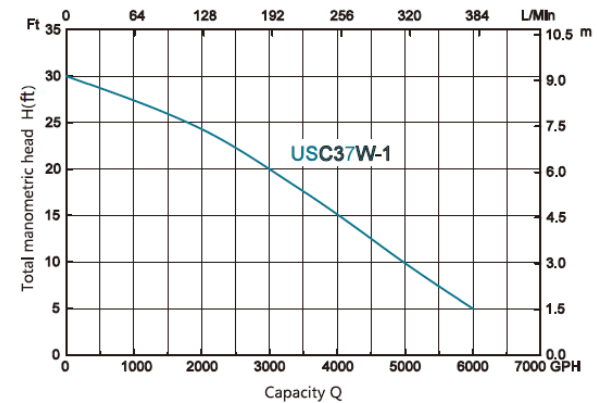

| Model | HP | Voltage | AMP | Discharge NPT(In) | GPH of water @ Total Ft. of Head | | | | | Max.Head Ft |
|--------------------|-----|---------|-----|-------------------|----------------------------------|-------|-------|-------|-------|-------------|
| | | | | | 5 ft | 10 ft | 15 ft | 20 ft | 25 ft | |
| USC37W-1-20 | 1/2 | 120 | 9.5 | 2 | 6000 | 4950 | 4050 | 3000 | 1950 | 30 |

Model #USC56W-1

3/4 HP Cast Iron Sewage Pump

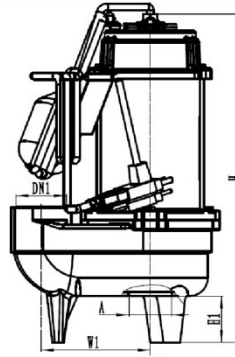

Features & Benefits:

- ❖ Durable cast iron construction.
- ❖ Heavy-duty cast-iron volute and nylon impeller.
- ❖ Built-in automatic thermal overload protector motor.
- ❖ Adjustable tethered or piggyback float switch for automatic operation.
- ❖ Application up to 2" diameter solids.
- ❖ 2" NPT discharge.
- ❖ 10ft power cord.
- ❖ 2-year warranty.

| | |
|---------------------|---------------------------------------|
| Inlet | 2 inch |
| Discharge | NPT2 |
| Pump Cover | HT200 |
| Motor Housing | 08F |
| Pump Body | HT200 |
| Switch Type | Float switch |
| Impeller | PA6-GF25 |
| Seal Design | Mechanical seal |
| Seal Material | Carborundum & Carborundum |
| Oil Filled Motor | Yes |
| Power Cord | SJTW3*18AWG |
| Net Weight (lbs) | 33 lbs |
| Gross Weight (lbs) | 36 lbs |
| Package Size | 11.2*7.5*17.6 inches |
| Expected Life Cycle | ON 10 Sec. OFF 30 Sec. 100,000 cycles |
| Motor Wires | Copper |
| Self-Priming | No |
| Certification | CSA |

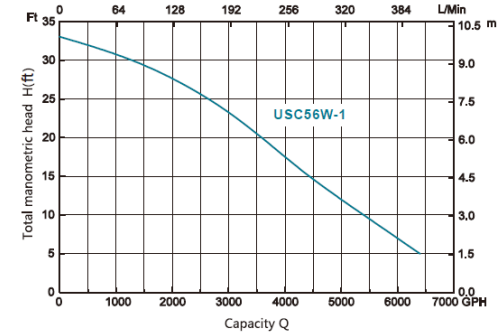

| Model | HP | Voltage | AMP | Discharge NPT(In) | GPH of water @ Total Ft. of Head | | | | | Max.Head Ft |
|-----------------|-----|---------|-----|-------------------|----------------------------------|-------|-------|-------|-------|-------------|
| | | | | | 5 ft | 10 ft | 15 ft | 20 ft | 25 ft | |
| USC56W-1 | 3/4 | 120 | 10 | 2 | 6400 | 5400 | 4400 | 3600 | 2700 | 33 |

Model #USC56W-1-20

3/4 HP Cast Iron Sewage Pump

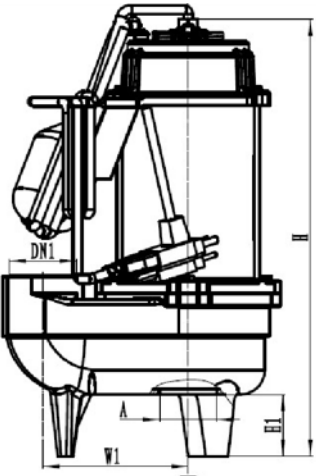

- Features & Benefits:**
- ❖ Durable cast iron construction.
 - ❖ Heavy-duty cast-iron volute and nylon impeller.
 - ❖ Built-in automatic thermal overload protector motor.
 - ❖ Adjustable tethered or piggyback float switch for automatic operation.
 - ❖ Application up to 2" diameter solids.
 - ❖ 2" NPT discharge.
 - ❖ 20ft power cord.
 - ❖ 2-year warranty.

| | |
|---------------------|---------------------------------------|
| Inlet | 2 inch |
| Discharge | NPT2 |
| Pump Cover | HT200 |
| Motor Housing | O8F |
| Pump Body | HT200 |
| Switch Type | Float switch |
| Impeller | PA6-GF25 |
| Seal Design | Mechanical seal |
| Seal Material | Carborundum & Carborundum |
| Oil Filled Motor | Yes |
| Power Cord | SJTW3*18AWG |
| Net Weight (lbs) | 38 |
| Gross Weight (lbs) | 40 |
| Package Size | 11.2*7.5*17.1 |
| Expected Life Cycle | ON 10 Sec. OFF 30 Sec. 100,000 cycles |
| Motor Wires | Copper |
| Self-Priming | No |
| Certification | CSA |

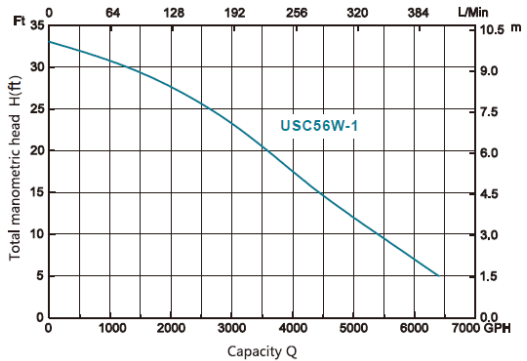

| Model | HP | Voltage | AMP | Discharge NPT(In) | GPH of water @ Total Ft. of Head | | | | | Max.Head Ft |
|---------------------|-----|---------|-----|-------------------|----------------------------------|-------|-------|-------|-------|-------------|
| | | | | | 5 ft | 10 ft | 15 ft | 20 ft | 25 ft | |
| USC-56W-1-20 | 3/4 | 120 | 9.5 | 2 | 6400 | 5400 | 4400 | 3600 | 2700 | 33 |

Model #UJM50-2

1 HP Dual Voltage Cast Iron Shallow Well Jet Pump



Features & Benefits:

- ❖ For use with shallow well within 25ft.
- ❖ Durable cast iron pump body.
- ❖ Built-in automatic thermal overload protection.
- ❖ Dual voltage motor (115/230V), Factory set for 115V.
- ❖ Pressure switch pre-set at 30-50 PSI.
- ❖ 1 ¼" NPT discharge and 1" NPT discharge.
- ❖ NEMA Motor.
- ❖ 3-year warranty.

| | |
|---------------------|-------------------------------------|
| Inlet | NPT 1 1/4 |
| Discharge | NPT1 |
| Pump Cover | / |
| Motor Housing | ZL102 |
| Pump Body | HT200 |
| Switch Type | Press switch |
| Impeller | PPO-GF30 |
| Seal Design | Mechanical seal |
| Seal Material | Graphite & Ceramic |
| Oil Filled Motor | No |
| Power Cord | / |
| Net Weight (lbs) | 44.4 |
| Gross Weight (lbs) | 51 |
| Package Size | 22.3*13.6*11.6 |
| Expected Life Cycle | ON 2 sec. OFF 2 sec. 300,000 cycles |
| Motor Wires | Copper |
| Self-Priming | Yes |
| Certification | UL |

Hydraulic Performance Curves

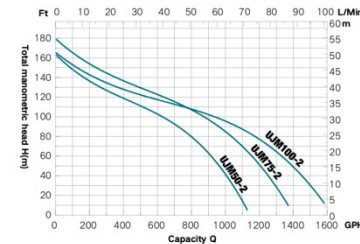

| Model | HP | Voltage | AMP | Discharge NPT(In) | GPH of water @ Total Ft. of Head | | | | | Max.Head Ft |
|----------------|----|---------|--------|-------------------|----------------------------------|-------|-------|--------|--------|-------------|
| | | | | | 5 ft | 35 ft | 70 ft | 100 ft | 130 ft | |
| UJM50-2 | 1 | 115/230 | 13/6.5 | 1 | 1150 | 1050 | 960 | 630 | 260 | 162 |

Model #UJM100-2

1 HP Dual Voltage Cast Iron Shallow Well Jet Pump



Features & Benefits:

- ❖ For use with shallow well within 25ft.
- ❖ Durable cast iron pump body.
- ❖ Built-in automatic thermal overload protection.
- ❖ Dual voltage motor (115/230V), Factory set for 230V.
- ❖ Pressure switch pre-set at 30-50 PSI.
- ❖ 1 ¼" NPT discharge and 1" NPT discharge.
- ❖ NEMA Motor.
- ❖ 3-year warranty.

| | |
|---------------------|-------------------------------------|
| Inlet | NPT 1 1/4 |
| Discharge | NPT1 |
| Pump Cover | / |
| Motor Housing | ZL102 |
| Pump Body | HT200 |
| Switch Type | Press switch |
| Impeller | PPO-GF30 |
| Seal Design | Mechanical seal |
| Seal Material | Graphite & Ceramic |
| Oil Filled Motor | No |
| Power Cord | / |
| Net Weight (lbs) | 49 |
| Gross Weight (lbs) | 51 |
| Package Size | 22.3*13.6*11.6 |
| Expected Life Cycle | ON 2 sec. OFF 2 sec. 300,000 cycles |
| Motor Wires | Copper |
| Self-Priming | Yes |
| Certification | UL |

Hydraulic Performance Curves

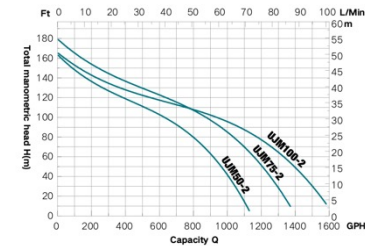

| Model | HP | Voltage | AMP | Discharge NPT(In) | GPH of water @ Total Ft. of Head | | | | | Max.Head Ft |
|-----------------|----|---------|------|-------------------|----------------------------------|-------|-------|--------|--------|-------------|
| | | | | | 5 ft | 35 ft | 70 ft | 100 ft | 130 ft | |
| UJM100-2 | 1 | 115/230 | 16/8 | 1 | 1550 | 1500 | 1270 | 950 | 500 | 180 |

Model #XKJ-1105S

1 ½ HP Irrigation/Lawn Sprinkler Pump

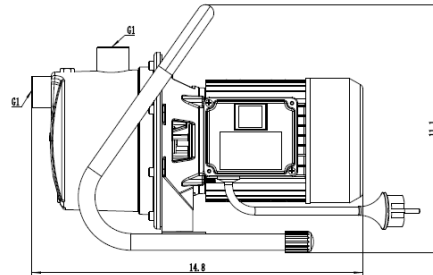

| | |
|---------------------|-----------------------------|
| Inlet | NPT1 |
| Discharge | NPT1 |
| Pump Cover | ZL102 |
| Motor Housing | ZL102 |
| Pump Body | Stainless steel |
| Switch Type | Water-proof switch_KCD4(UL) |
| Impeller | PPO-GF30 |
| Seal Design | Mechanical seal |
| Seal Material | Graphite & Ceramic |
| Oil Filled Motor | No |
| Power Cord | YY-3_3C*SJTW 16AWG*6.6ft |
| Net Weight (lbs) | 23 |
| Gross Weight (lbs) | 28 |
| Package Size | 15.4*9.9*10.8 |
| Expected Life Cycle | 4000 Hours |
| Motor Wires | Aluminum |
| Self-Priming | No |
| Certification | ETL |

Features & Benefits:

- ❖ Durable stainless-steel volute with front drain plug.
- ❖ Built-in automatic thermal overload protection.
- ❖ Permanent split capacitor motor.
- ❖ Reinforced thermoplastic impeller and corrosion resistant diffuser.
- ❖ Carbon/Ceramic mechanical seal.
- ❖ On/Off Switch.
- ❖ 1" NPT discharge.
- ❖ 6ft power cord.
- ❖ 1 year warranty.

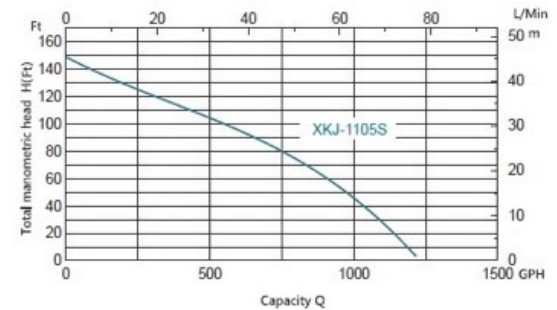

| Model | HP | Voltage | AMP | Discharge NPT(In) | GPH of water @ Total Ft. of Head | | | | Max.Head Ft |
|------------------|-------|---------|-----|-------------------|----------------------------------|-------|--------|--------|-------------|
| | | | | | 0 ft | 50 ft | 100 ft | 150 ft | |
| XKJ-1105S | 1-1/2 | 115 | 10 | 1 | 1200 | 980 | 580 | 0 | 150 |

Model #UJM50-1

1/2HP Dual Voltage Cast Iron Shallow Well Jet Pump

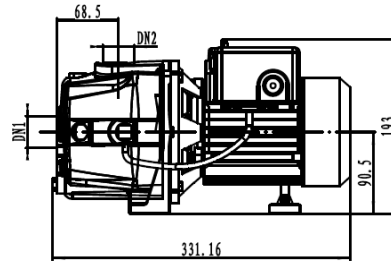

Features & Benefits:

- ❖ For use with shallow well within 25ft.
- ❖ Durable cast iron pump body.
- ❖ Built-in automatic thermal overload protection.
- ❖ Dual voltage motor (115/230V), Factory wired for 230V.
- ❖ Pressure switch pre-set at 30-50 PSI.
- ❖ 1 1/4" NPT suction and 1" NPT discharge.
- ❖ 2-year warranty.

| | |
|---------------------|-------------------------------------|
| Inlet | NPT1-1/4 |
| Discharge | NPT1 |
| Pump Cover | / |
| Motor Housing | ZL102 |
| Pump Body | HT200 |
| Switch Type | Press switch |
| Impeller | PPO-GF30 |
| Seal Design | Mechanical seal |
| Seal Material | Graphite & Ceramic |
| Oil Filled Motor | No |
| Power Cord | / |
| Net Weight (lbs) | 19 |
| Gross Weight (lbs) | 21 |
| Package Size | 16 x 10.5 x 9.5 |
| Expected Life Cycle | ON 2 sec. OFF 2 sec. 300,000 cycles |
| Motor Wires | Copper |
| Self-Priming | Yes |
| Certification | CSA |

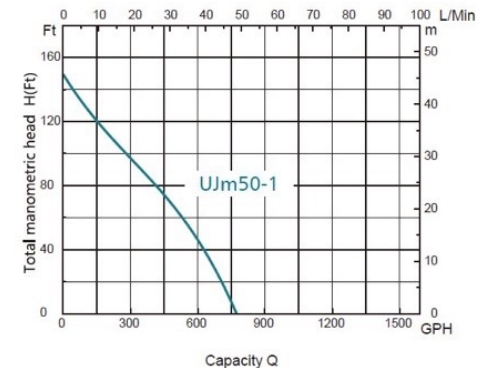

| Model | HP | Voltage | AMP | Discharge NPT(In) | GPH of water @ Total Ft. of Head | | | | | Max.Head Ft |
|----------------|-----|---------|---------|-------------------|----------------------------------|-------|-------|--------|--------|-------------|
| | | | | | 5 ft | 35 ft | 70 ft | 100 ft | 130 ft | |
| UJM50-1 | 1/2 | 115/230 | 6.6/3.3 | 1 | 790 | 660 | 580 | 300 | 75 | 147 |

Model #UJM75-1

3/4HP Dual Voltage Cast Iron Shallow Well Jet Pump

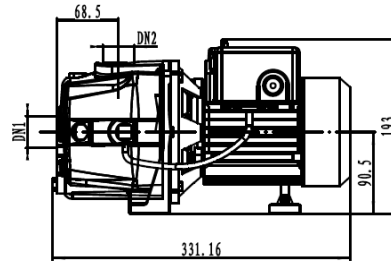

| | |
|---------------------|-------------------------------------|
| Inlet | NPT1-1/4 |
| Discharge | NPT1 |
| Pump Cover | / |
| Motor Housing | ZL102 |
| Pump Body | HT200 |
| Switch Type | Press switch |
| Impeller | PPO-GF30 |
| Seal Design | Mechanical seal |
| Seal Material | Graphite & Ceramic |
| Oil Filled Motor | No |
| Power Cord | / |
| Net Weight (lbs) | 19 |
| Gross Weight (lbs) | 21 |
| Package Size | 16 x 10.5 x 9.5 |
| Expected Life Cycle | ON 2 sec. OFF 2 sec. 300,000 cycles |
| Motor Wires | Copper |
| Self-Priming | Yes |
| Certification | CSA |

Features & Benefits:

- ❖ For use with shallow well within 25ft.
- ❖ Durable cast iron pump body.
- ❖ Built-in automatic thermal overload protection.
- ❖ Dual voltage motor (115/230V), Factory wired for 230V.
- ❖ Pressure switch pre-set at 30-50 PSI.
- ❖ 1 1/4" NPT suction and 1" NPT discharge.
- ❖ 2-year warranty.

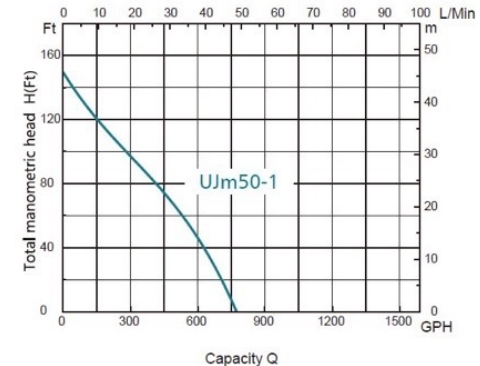

| Model | HP | Voltage | AMP | Discharge NPT(In) | GPH of water @ Total Ft. of Head | | | | | Max.Head Ft |
|----------------|-----|---------|-------|-------------------|----------------------------------|-------|-------|--------|--------|-------------|
| | | | | | 5 ft | 35 ft | 70 ft | 100 ft | 130 ft | |
| UJM75-1 | 3/4 | 115/230 | 9/4.5 | 1 | 1100 | 920 | 710 | 500 | 200 | 154 |

Model #UJM100-1

1HP Dual Voltage Cast Iron Shallow Well Jet Pump

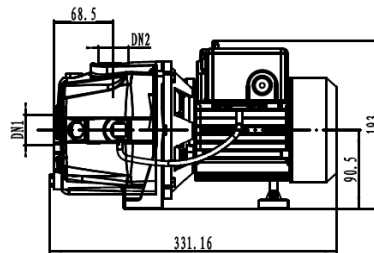

| | |
|---------------------|-------------------------------------|
| Inlet | NPT1-1/4 |
| Discharge | NPT1 |
| Pump Cover | / |
| Motor Housing | ZL102 |
| Pump Body | HT200 |
| Switch Type | Press switch |
| Impeller | PPO-GF30 |
| Seal Design | Mechanical seal |
| Seal Material | Graphite & Ceramic |
| Oil Filled Motor | No |
| Power Cord | / |
| Net Weight (lbs) | 33 |
| Gross Weight (lbs) | 36.5 |
| Package Size | 18.5*11.7*10 |
| Expected Life Cycle | ON 2 sec. OFF 2 sec. 300,000 cycles |
| Motor Wires | Copper |
| Self-Priming | Yes |
| Certification | CSA |

Features & Benefits:

- ❖ For use with shallow well within 25ft.
- ❖ Durable cast iron pump body.
- ❖ Built-in automatic thermal overload protection.
- ❖ Dual voltage motor (115/230V), Factory wired for 230V.
- ❖ Pressure switch pre-set at 30-50 PSI.
- ❖ 1 ¼" NPT suction and 1" NPT discharge.
- ❖ 2-year warranty.

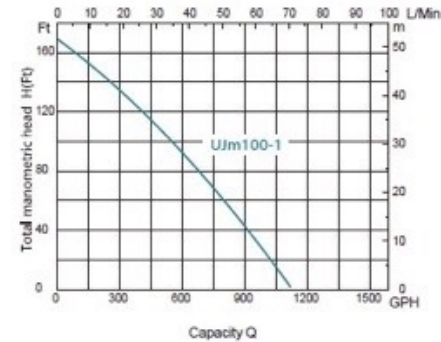

| Model | HP | Voltage | AMP | Discharge NPT(In) | GPH of water @ Total Ft. of Head | | | | | Max.Head Ft |
|-----------------|----|------------|---------|-------------------|----------------------------------|-------|-------|--------|--------|-------------|
| | | | | | 5 ft | 35 ft | 70 ft | 100 ft | 130 ft | |
| UJM100-1 | 1 | 115 or 230 | 9.6/4.8 | 1 | 1100 | 870 | 750 | 540 | 310 | 164 |

Model #UDPM50-1

½ HP Dual Voltage Cast Iron Convertible Jet Pump

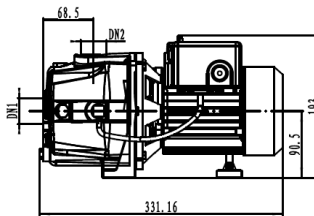

Features & Benefits:

- ❖ For use on shallow well applications up to 25ft water level.
- ❖ For use on deep well applications up to 25-100 feet.
- ❖ Durable cast iron pump body.
- ❖ Built-in automatic thermal overload protection.
- ❖ Dual voltage motor (115/230V), factory wired for 230V.
- ❖ Ejector is included for deep well usage.
- ❖ 1 ¼" NPT suction and 1" NPT discharge.
- ❖ 2-year warranty.

| | |
|---------------------|-------------------------------------|
| Inlet | NPT1-1/4 |
| Discharge | NPT1 |
| Pump Cover | / |
| Motor Housing | ZL102 |
| Pump Body | HT200 |
| Switch Type | Press switch |
| Impeller | PPO-GF30 |
| Seal Design | Mechanical seal |
| Seal Material | Graphite & Ceramic |
| Oil Filled Motor | No |
| Power Cord | / |
| Net Weight (lbs) | 23.9 |
| Gross Weight (lbs) | 26.5 |
| Package Size | 15*10.2*9 |
| Expected Life Cycle | ON 2 sec. OFF 2 sec. 300,000 cycles |
| Motor Wires | Copper |
| Self-Priming | No |
| Certification | CSA |

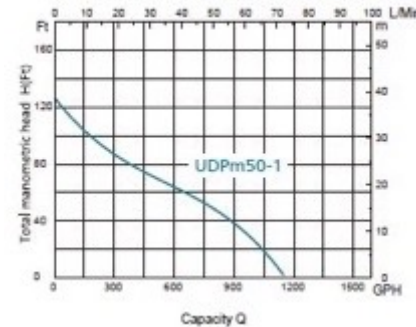

| Model | HP | Voltage | AMP | Discharge NPT(In) | GPH of water @ Total Ft. of Head | | | | | Max.Head Ft |
|-----------------|------------|---------|---------|-------------------|----------------------------------|-------|-------|--------|--------|-------------|
| | | | | | 5 ft | 35 ft | 70 ft | 100 ft | 128 ft | |
| UDPM50-1 | 1/2 | 115/230 | 8.8/4.4 | 1 | 1100 | 950 | 650 | 200 | / | 128 |

Model #UDPM75-1

3/4HP Dual Voltage Cast Iron Convertible Jet Pump

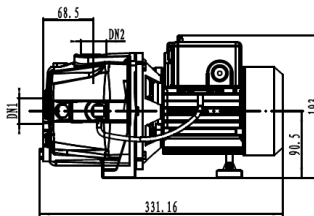

Features & Benefits:

- ❖ For use on shallow well applications up to 25ft water level.
- ❖ For use on deep well applications up to 25-130 feet.
- ❖ Durable cast iron pump body.
- ❖ Built-in automatic thermal overload protection.
- ❖ Dual voltage motor (115/230V), factory wired for 230V.
- ❖ Ejector is included for deep well usage.
- ❖ 1 ¼" NPT suction and 1" NPT discharge.
- ❖ 2-year warranty.

| | |
|---------------------|-------------------------------------|
| Inlet | NPT1-1/4 |
| Discharge | NPT1 |
| Pump Cover | / |
| Motor Housing | ZL102 |
| Pump Body | HT200 |
| Switch Type | Press switch |
| Impeller | PPO-GF30 |
| Seal Design | Mechanical seal |
| Seal Material | Graphite & Ceramic |
| Oil Filled Motor | No |
| Power Cord | / |
| Net Weight (lbs) | 30 |
| Gross Weight (lbs) | 35 |
| Package Size | 16.3*11.4*9.6 |
| Expected Life Cycle | ON 2 sec. OFF 2 sec. 300,000 cycles |
| Motor Wires | Copper |
| Self-Priming | No |
| Certification | CSA |

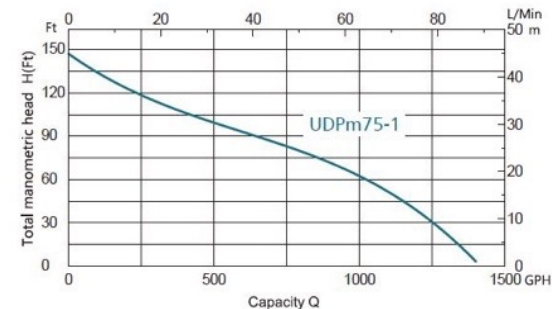

| Model | HP | Voltage | AMP | Discharge NPT(In) | GPH of water @ Total Ft. of Head | | | | | Max.Head Ft |
|-----------------|-----|---------|----------|-------------------|----------------------------------|-------|-------|--------|--------|-------------|
| | | | | | 5 ft | 35 ft | 70 ft | 100 ft | 130 ft | |
| UDPM75-1 | 3/4 | 115/230 | 12.6/6.3 | 1 | 1400 | 1220 | 900 | 430 | 125 | 147 |

Model #UDPM100-1

1HP Dual Voltage Cast Iron Convertible Jet Pump

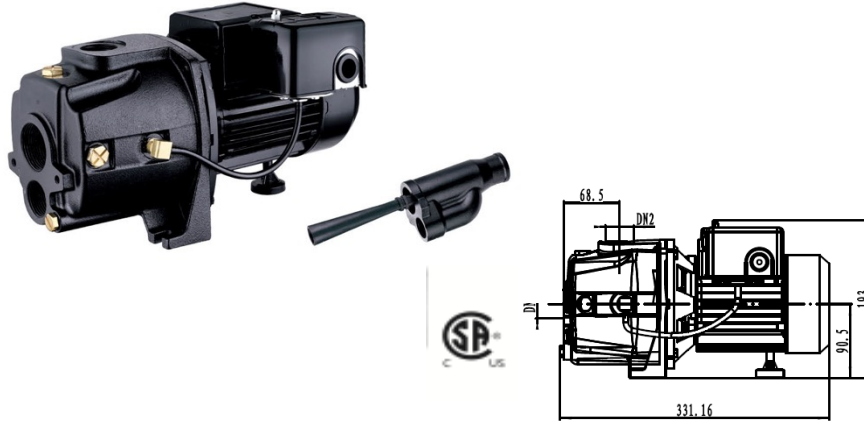

Features & Benefits:

- ❖ For use on shallow well applications up to 25ft water level.
- ❖ For use on deep well applications up to 25-310 feet.
- ❖ Durable cast iron pump body.
- ❖ Built-in automatic thermal overload protection.
- ❖ Dual voltage motor (115/230V), factory wired for 230V.
- ❖ Ejector is included for deep well usage.
- ❖ 1 ¼" NPT suction and 1" NPT discharge.
- ❖ 2-year warranty.

| | |
|---------------------|-------------------------------------|
| Inlet | NPT1-1/4 |
| Discharge | NPT1 |
| Pump Cover | / |
| Motor Housing | ZL102 |
| Pump Body | HT200 |
| Switch Type | Press switch |
| Impeller | PPO-GF30 |
| Seal Design | Mechanical seal |
| Seal Material | Graphite & Ceramic |
| Oil Filled Motor | No |
| Power Cord | / |
| Net Weight (lbs) | 33 |
| Gross Weight (lbs) | 36.5 |
| Package Size | 16.3*11.4*9.6 |
| Expected Life Cycle | ON 2 sec. OFF 2 sec. 300,000 cycles |
| Motor Wires | Copper |
| Self-Priming | No |
| Certification | CSA |

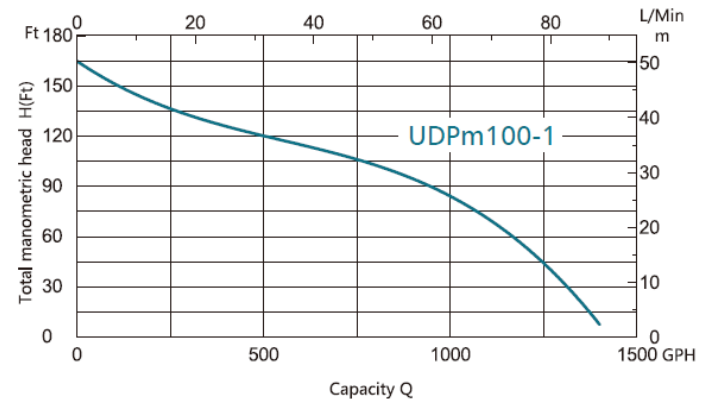

| Model | HP | Voltage | AMP | Discharge NPT(In) | GPH of water @ Total Ft. of Head | | | | | Max.Head Ft |
|------------------|----|-----------|----------|-------------------|----------------------------------|-------|-------|--------|--------|-------------|
| | | | | | 5 ft | 35 ft | 70 ft | 100 ft | 130 ft | |
| UDPM100-1 | 1 | 115 / 230 | 15.4/7.7 | 1 | 1400 | 1320 | 1050 | 790 | 310 | 164 |

Model #XKJ-1104SE

1 ½ HP Stainless Steel Tankless Booster Pump

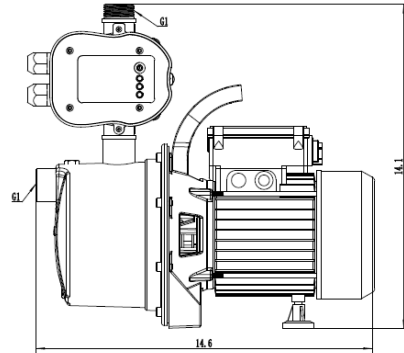

| | |
|---------------------|------------------------------|
| Inlet | NPT1 |
| Discharge | NPT1 |
| Pump Cover | ZL102 |
| Pump Body | 304 |
| Switch Type | Water-proof switch _KCD4(UL) |
| Impeller | PPO-GF30 |
| Seal Design | Mechanical seal |
| Seal Material | Graphite & Ceramic |
| Oil Filled Motor | No |
| Power Cord | 16AWG*6.4ft (16AWG*1.6ft) |
| Net Weight | 22.7 |
| Gross Weight | 25.4 |
| Package Size | 24.9*11.02*10.83 |
| Expected Life Cycle | 4000 Hours |
| Motor Wires | Aluminum |
| Self-Priming | No |
| Certification | ETL |

Features & Benefits:

- ❖ For use on shallow well applications up to 164ft water level.
- ❖ Mounted with a pressure regulator.
- ❖ Electronic system eliminates the conventional tanks & pressure switch.
- ❖ Regulates and controls rate and flow of water.
- ❖ Protects pumps from running dry when low water level in well.
- ❖ 6ft power cord.
- ❖ 2-year warranty.

Hydraulic Performance Curves

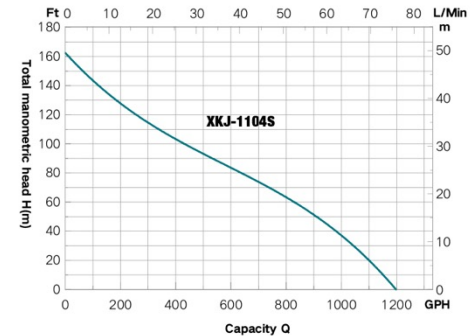

| Model | HP | Voltage | AMP | Discharge NPT(In) | GPH of water @ Total Ft. of Head | | | | | Max.Head Ft |
|-------------------|-------|---------|-----|-------------------|----------------------------------|-------|-------|-------|-------|-------------|
| | | | | | 0 ft | 20 ft | 40 ft | 60 ft | 80 ft | |
| XKJ-1104SE | 1-1/2 | 115 | 10 | 1 | 1210 | 1100 | 980 | 850 | | 164 |

Model #UJM50-1A3

½ HP Shallow Well Jet Pump C/W Pressure Tank

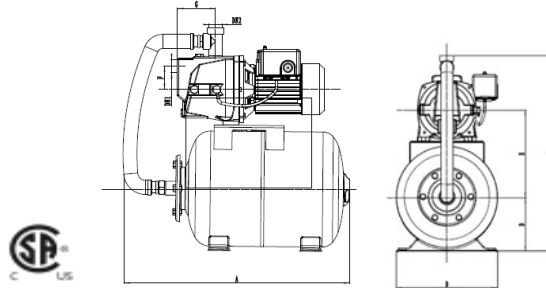

Features & Benefits:

- ❖ For use on shallow well applications up to 25ft water level.
- ❖ Durable cast iron pump housing.
- ❖ Built-in thermal overload protection.
- ❖ Fully automatic water supply.
- ❖ Dedicated priming port for volute filling.
- ❖ 1 ¼" NPT suction and 1" NPT discharge.
- ❖ Complete with 6-gallon tank.
- ❖ 2-year warranty.

| | |
|---------------------|------------------------------------|
| Inlet | NPT1-1/4 |
| Discharge | NPT1 |
| Pump Cover | / |
| Motor Housing | ZL102 |
| Pump Body | HT200 |
| Switch Type | Press switch |
| Impeller | PPO-GF30 |
| Seal Design | Mechanical seal |
| Seal Material | Graphite & Ceramic |
| Oil Filled Motor | No |
| Power Cord | / |
| Net Weight (lbs) | 19 |
| Gross Weight (lbs) | 21.7 |
| Package Size | 22.8*15.5*21.1 |
| Expected Life Cycle | ON 2 SEC OFF 2 sec. 300,000 cycles |
| Motor Wires | Copper |
| Self-Priming | No |
| Certification | CSA |

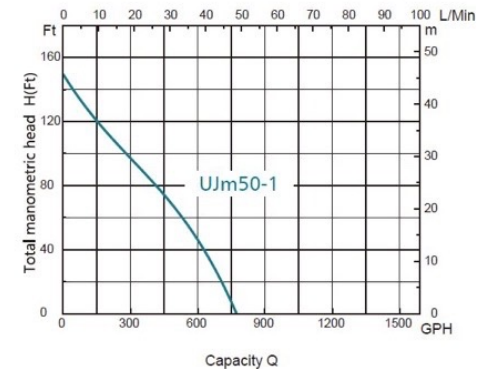

| Model | HP | Voltage | AMP | Discharge NPT(In) | GPH of water @ Total Ft. of Head | | | | | Max.Head Ft |
|------------------|-----|---------|---------|-------------------|----------------------------------|-------|-------|--------|--------|-------------|
| | | | | | 5 ft | 35 ft | 70 ft | 100 ft | 130 ft | |
| UJM50-1A3 | 1/2 | 115/230 | 6.6/3.3 | 1 | 790 | 660 | 580 | 300 | 75 | 147 |

Model #UJM100-1A3

1 HP Shallow Well Jet Pump C/W Pressure Tank

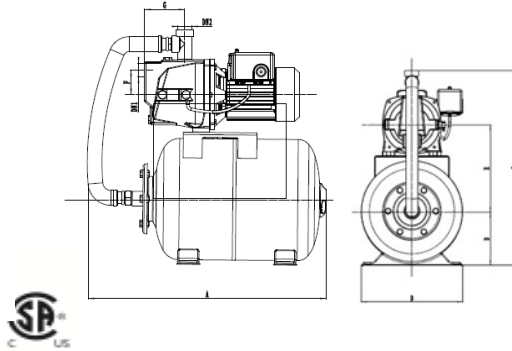

Features & Benefits:

- ❖ For use on shallow well applications up to 25ft water level.
- ❖ Durable cast iron pump housing.
- ❖ Built-in thermal overload protection.
- ❖ Fully automatic water supply.
- ❖ Dedicated priming port for volute filling.
- ❖ 1 ¼" NPT suction and 1" NPT discharge.
- ❖ Complete with 6-gallon tank.
- ❖ 2-year warranty.

| | |
|---------------------|------------------------------------|
| Inlet | NPT1-1/4 |
| Discharge | NPT1 |
| Pump Cover | / |
| Motor Housing | ZL102 |
| Pump Body | HT200 |
| Switch Type | Press switch |
| Impeller | PPO-GF30 |
| Seal Design | Mechanical seal |
| Seal Material | Graphite & Ceramic |
| Oil Filled Motor | No |
| Power Cord | / |
| Net Weight (lbs) | 29 |
| Gross Weight (lbs) | 32 |
| Package Size | 20.3*12.4*22.3 |
| Expected Life Cycle | ON 2 SEC OFF 2 sec. 300,000 cycles |
| Motor Wires | Copper |
| Self-Priming | No |
| Certification | CSA |

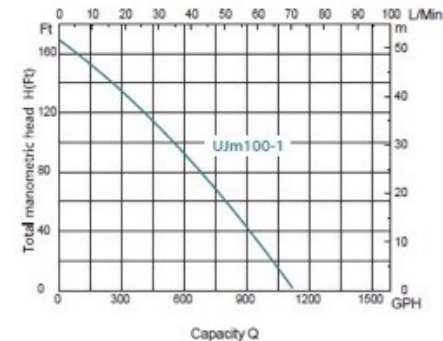

| Model | HP | Voltage | AMP | Discharge NPT (In) | GPH of water @ Total Ft. of Head | | | | | Max.Head Ft |
|-------------------|----|------------|---------|--------------------|----------------------------------|-------|-------|--------|--------|-------------|
| | | | | | 5 ft | 35 ft | 70 ft | 100 ft | 130 ft | |
| UJM100-1A3 | 1 | 115 or 230 | 9.6/4.8 | 1 | 1100 | 870 | 750 | 540 | 310 | 164 |

Model #DWS050-2

Submersible Deep Well Pump



Features & Benefits:

- Fits inside any 4" opening
- Water cooled submersible motor
- Corrosion-resistant stainless-steel pump and motor housing
- 2-wire installation does not require a control box
- 1-1/4" NPT discharge designed to fit most applications
- 5-year warranty

| | |
|---------------------|-------------------------------------|
| Inlet | / |
| Discharge | NPT1-1/4 |
| Pump Cover | / |
| Motor Housing | AISI304 |
| Pump Body | AISI304 |
| Switch Type | / |
| Impeller | AISI304 |
| Seal Design | Motor laser welding seal |
| Seal Material | / |
| Oil Filled Motor | Water filled |
| Power Cord | 2 wires, UL3173 14AWG ,length:1m |
| Net Weight (lbs) | 26.4 lbs |
| Gross Weight (lbs) | 27. 8lbs |
| Package Size | 24.4*5.5*5.9 inches |
| Expected Life Cycle | On 2 sec. Off 2 sec. 300,000 cycles |
| Motor Wires | Copper |
| Self-Priming | No |
| Certification | CSA |

Hydraulic Performance Curves

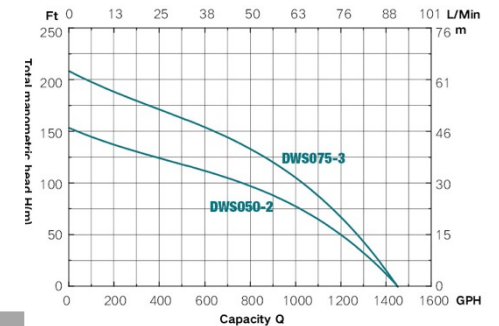

| Model | HP | Voltage | Discharge NPT(In) | GPH of water @ Total Ft. of Head | | | | | Max. Head Ft |
|----------|-----|---------|----------------------|----------------------------------|-------|--------|--------|--------|-----------------|
| | | | | 0 ft | 50 ft | 100 ft | 150 ft | 200 ft | |
| DWS050-2 | 1/2 | 230V | 1-1/4 in | 1450 | 1190 | 785 | 700 | 30 | 155 |
| DWS075-3 | 3/4 | 230V | 1-1/4 in | 1454 | 1280 | 1050 | 650 | 95 | 210 |
| | | | | | | | | | |
| | | | | | | | | | |

31

Model #DWS075-3

Submersible Deep Well Pump



Features & Benefits:

- Fits inside any 4" opening
- Water cooled submersible motor
- Corrosion-resistant stainless-steel pump and motor housing
- 3-wire pumps must be used with the correct control box (included)
- 1-1/4" NPT discharge designed to fit most applications
- 5-year warranty

| | |
|---------------------|-------------------------------------|
| Inlet | / |
| Discharge | NPT1-1/4 |
| Pump Cover | / |
| Motor Housing | AISI304 |
| Pump Body | AISI304 |
| Switch Type | / |
| Impeller | AISI304 |
| Seal Design | Motor laser welding seal |
| Seal Material | / |
| Oil Filled Motor | Water filled |
| Power Cord | 3 wires UL3173 14AWG, length: 1m |
| Net Weight (lbs) | 30.8 lbs |
| Gross Weight (lbs) | 33.0 lbs |
| Package Size | 35.0*7.5*5.9 inches |
| Expected Life Cycle | On 2 sec. Off 2 sec. 300,000 cycles |
| Motor Wires | Copper |
| Self-Priming | No |
| Certification | CSA |

Hydraulic Performance Curves

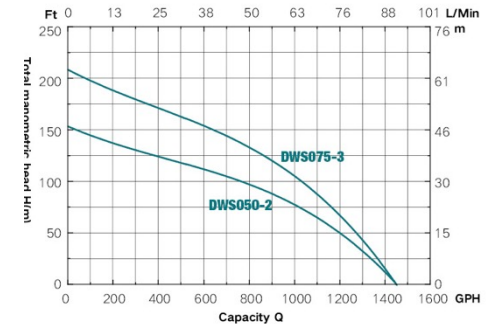

| Model | HP | Voltage | Discharge NPT(In) | GPH of water @ Total Ft. of Head | | | | | Max. Head Ft |
|----------|-----|---------|----------------------|----------------------------------|-------|--------|--------|--------|-----------------|
| | | | | 0 ft | 50 ft | 100 ft | 150 ft | 200 ft | |
| DWS050-2 | 1/2 | 230V | 1-1/4 in | 1450 | 1190 | 785 | 700 | 30 | 155 |
| DWS075-3 | 3/4 | 230V | 1-1/4 in | 1454 | 1280 | 1050 | 650 | 95 | 210 |
| | | | | | | | | | |

32

24 Liter / 6 Gallon Horizontal Water Pressure Tank



PRODUCT INFORMATION

Triple coated tough, appliance-like finish for extended life
 Heavy gauge steel construction for maximum durability
 Stainless steel water connector
 Factory pre-charged at 30 PSI
 Convenient air valve location for quick hook up
 No water to metal contact; rust-free operation
 Air Sealed Diaphragm. NSF certified butyl rubber diaphragm 100%
 Air Seal
 Certified to ANSI/NSF 61

| Model Number | | HT-24H | | | |
|----------------------------|-------------|------------------------------|--------------------|----------|------|
| Customer SKU Number | | | | | |
| | | FOB | Vaughan, ON | | |
| SPECIFICATIONS | | Retail Box Dimensions | | | |
| | | Inches | | Cm | |
| Tank Orientation | Horizontal | H | 13.6 | H | 34.6 |
| Certified | NSF 61 | W | 17.1 | W | 43.5 |
| Color/Finish | Blue | D | 11.0 | D | 30.0 |
| Discharge outlet size | 1 inch | Wt. (lb) | 11.9 | Wt. (kg) | 5.4 |
| Outlet Connection size | 1 inch | Product Dimensions | | | |
| Tank Material | Steel | inches | | cm | |
| Tank Capacity | 24L/6Ga | H | 12.8 | H | 32.6 |
| Precharge PSI | 40 | W | 16.3 | W | 41.5 |
| Maximum Working Pressure | 120 PSI | D | 11.4 | D | 29.0 |
| Diameter | 29cm/11.4in | Wt. (lb) | 10.6 | Wt. (kg) | 4.8 |

80 Liter / 20 Gallon Horizontal Water Pressure Tank



PRODUCT INFORMATION

Triple coated tough, appliance-like finish for extended life
 Heavy gauge steel construction for maximum durability
 Stainless steel water connector
 Factory pre-charged at 30 PSI
 Convenient air valve location for quick hook up
 No water to metal contact; rust-free operation
 Air Sealed Diaphragm. NSF certified butyl rubber diaphragm 100%
 Air Seal
 Certified to ANSI/NSF 61

| Model Number | | HT-80H | | | |
|----------------------------|-------------|------------------------------|--------------------|----------|------|
| Customer SKU Number | | | | | |
| | | FOB | Vaughan, ON | | |
| SPECIFICATIONS | | Retail Box Dimensions | | | |
| | | Inches | | Cm | |
| Tank Orientation | Horizontal | H | 19.2 | H | 48.8 |
| Certified | NSF 61 | W | 24.9 | W | 63.3 |
| Color/Finish | Blue | D | 17.5 | D | 44.5 |
| Discharge outlet size | 1 inch | Wt. (lb) | 29.8 | Wt. (kg) | 13.5 |
| Outlet Connection size | 1 inch | Product Dimensions | | | |
| Tank Material | Steel | inches | | cm | |
| Tank Capacity | 80L/20Ga | H | 18.5 | H | 46.9 |
| Precharge PSI | 40 | W | 24.5 | W | 62.2 |
| Maximum Working Pressure | 120 PSI | D | 17.0 | D | 43.2 |
| Diameter | 43.2cm/17in | Wt. (lb) | 26.5 | Wt. (kg) | 12.0 |

18 Liter / 4.5 Gallon Vertical Water Pressure Tank



PRODUCT INFORMATION

Triple coated tough, appliance-like finish for extended life
 Heavy gauge steel construction for maximum durability
 Stainless steel water connector
 Factory pre-charged at 30 PSI
 Convenient air valve location for quick hook up
 No water to metal contact; rust-free operation
 Air Sealed Diaphragm. NSF certified butyl rubber diaphragm 100%
 Air Seal
 Certified to ANSI/NSF 61

| Model Number | | HT-18 | | | |
|----------------------------|-------------|------------------------------|--------------------|----------|------|
| Customer SKU Number | | | | | |
| | | FOB | Vaughan, ON | | |
| SPECIFICATIONS | | Retail Box Dimensions | | | |
| | | Inches | | Cm | |
| Tank Orientation | Vertical | H | 15.2 | H | 38.5 |
| Certified | NSF 61 | W | 11.4 | W | 29.0 |
| Color/Finish | Blue | D | 11.4 | D | 29.0 |
| Discharge outlet size | 1 inch | Wt. (lb) | 8.16 | Wt. (kg) | 3.7 |
| Outlet Connection size | 1 inch | Product Dimensions | | | |
| Tank Material | Steel | inches | | cm | |
| Tank Capacity | | H | 14.3 | H | 36.4 |
| Precharge PSI | 40 | W | 11 | W | 28.0 |
| Maximum Working Pressure | 120 PSI | D | 11 | D | 28.0 |
| Diameter | 28cm/11.0in | Wt. (lb) | 7.28 | Wt. (kg) | 3.3 |

80 Liter / 20 Gallon Vertical Water Pressure Tank



PRODUCT INFORMATION

Triple coated tough, appliance-like finish for extended life
 Heavy gauge steel construction for maximum durability
 Stainless steel water connector
 Factory pre-charged at 30 PSI
 Convenient air valve location for quick hook up
 No water to metal contact; rust-free operation
 Air Sealed Diaphragm. NSF certified butyl rubber diaphragm 100%
 Air Seal
 Certified to ANSI/NSF 61

| Model Number | | HT-80 | | | |
|----------------------------|-------------|------------------------------|--------------------|----------|------|
| Customer SKU Number | | | | | |
| | | FOB | Vaughan, ON | | |
| SPECIFICATIONS | | Retail Box Dimensions | | | |
| | | Inches | | Cm | |
| Tank Orientation | Vertical | H | 28.0 | H | 71.0 |
| Certified | NSF 61 | W | 17.3 | W | 44.0 |
| Color/Finish | Blue | D | 17.3 | D | 44.0 |
| Discharge outlet size | 1 inch | Wt. (lb) | 30.9 | Wt. (kg) | 14.0 |
| Outlet Connection size | 1 inch | Product Dimensions | | | |
| Tank Material | Steel | inches | | cm | |
| Tank Capacity | | H | 27.3 | H | 60.3 |
| Precharge PSI | 40 | W | 17 | W | 43.2 |
| Maximum Working Pressure | 120 PSI | D | 17 | D | 43.2 |
| Diameter | 43.2cm/17in | Wt. (lb) | 26.7 | Wt. (kg) | 12.1 |

100 Liter / 28 Gallon Vertical Water Pressure Tank



PRODUCT INFORMATION

Triple coated tough, appliance-like finish for extended life
 Heavy gauge steel construction for maximum durability
 Stainless steel water connector
 Factory pre-charged at 30 PSI
 Convenient air valve location for quick hook up
 No water to metal contact; rust-free operation
 Air Sealed Diaphragm. NSF certified butyl rubber diaphragm 100%
 Air Seal
 Certified to ANSI/NSF 61

| Model Number | | HT-100 | | | |
|----------------------------|-------------|------------------------------|--------------------|----------|------|
| Customer SKU Number | | | | | |
| | | FOB | Vaughan, ON | | |
| SPECIFICATIONS | | Retail Box Dimensions | | | |
| | | Inches | | Cm | |
| Tank Orientation | Vertical | H | 31.0 | H | 78.8 |
| Certified | NSF 61 | W | 17.3 | W | 44.0 |
| Color/Finish | Blue | D | 17.3 | D | 44.0 |
| Discharge outlet size | 1 inch | Wt. (lb) | 33.0 | Wt. (kg) | 15.2 |
| Outlet Connection size | 1 inch | Product Dimensions | | | |
| Tank Material | Steel | inches | | cm | |
| Tank Capacity | | H | 30.1 | H | 76.5 |
| Precharge PSI | 40 | W | 16.9 | W | 43.0 |
| Maximum Working Pressure | 120 PSI | D | 16.9 | D | 43.0 |
| Diameter | 43cm/16.9in | Wt. (lb) | 29.3 | Wt. (kg) | 13.3 |

130 Liter / 34 Gallon Vertical Water Pressure Tank



PRODUCT INFORMATION

Triple coated tough, appliance-like finish for extended life
 Heavy gauge steel construction for maximum durability
 Stainless steel water connector
 Factory pre-charged at 30 PSI
 Convenient air valve location for quick hook up
 No water to metal contact; rust-free operation
 Air Sealed Diaphragm. NSF certified butyl rubber diaphragm 100%
 Air Seal
 Certified to ANSI/NSF 61

| Model Number | | HT-130 | | | |
|----------------------------|-------------|------------------------------|--------------------|----------|------|
| Customer SKU Number | | | | | |
| | | FOB | Vaughan, ON | | |
| SPECIFICATIONS | | Retail Box Dimensions | | | |
| | | Inches | | Cm | |
| Tank Orientation | Vertical | H | 31.9 | H | 80.5 |
| Certified | NSF 61 | W | 22.1 | W | 56.0 |
| Color/Finish | Blue | D | 22.1 | D | 56.0 |
| Discharge outlet size | 1 1/4 inch | Wt. (lb) | 54.1 | Wt. (kg) | 24.5 |
| Outlet Connection size | 1 inch | Product Dimensions | | | |
| Tank Material | Steel | inches | | cm | |
| Tank Capacity | | H | 30.9 | H | 78.5 |
| Precharge PSI | 40 | W | 21.7 | W | 55.0 |
| Maximum Working Pressure | 120 PSI | D | 21.7 | D | 55.0 |
| Diameter | 55cm/21.7in | Wt. (lb) | 47.4 | Wt. (kg) | 21.5 |

8Liter / 2.0 Gallon Thermal Expansion Tank



PRODUCT INFORMATION

- Built with a stainless steel system connection with patented Leak safe technology.
- Inside the tank is a Heavy-duty, butyl rubber diaphragm with 400% elongation physical property.
- A polypropylene liner separates the water from the pre-charged air chamber.
- The tank controls excessive pressure generated inside the water heater using sealed compressible air cushion space to store and hold the addition expansion water volume.
- Factory Pre-charge 40PSI Nitrogen.
- NSF 61

| | | | | | |
|----------------------------|--------------|--------------------------|--------------------------|------------|------|
| Model Number | | HTP-8 | | | |
| Customer SKU Number | | | | | |
| Price (CAD) | | FOB Port | Toronto Warehouse | | |
| SPECIFICATIONS | | MOQ | | 40' Qty | 4380 |
| Tank Orientation | Vertical | Case Pack | 1 | 40' HC Qty | 5170 |
| Certified | | Master Carton Dimensions | | | |
| Color/Finish | Grey | inches | | cm | |
| Discharge outlet size | 3/4 inch | H | | H | |
| Outlet Connection size | 3/4 inch | W | | W | |
| Tank Material | Steel | D | | D | |
| Tank Capacity | 8L/2.0Ga | Wt. (lb) | | Wt. (kg) | |
| Test Pressure | 14.5 Bar | Retail Box Dimensions | | | |
| Maximum Working Pressure | 10.0 Bar | Inches | | Cm | |
| Diameter | 20.3cm/8.0in | H | 12.4 | H | 31.5 |
| MAX. Operating Temp. | 90 Degree C | W | 8.5 | W | 21.5 |
| | | D | 8.5 | D | 21.5 |
| | | Wt. (lb) | 5.07 | Wt. (kg) | 2.3 |
| | | Product Dimensions | | | |
| | | inches | | cm | |
| | | H | 11.4 | H | 29.0 |
| | | W | 8.0 | W | 20.3 |
| | | D | 8.0 | D | 20.3 |
| | | | | Wt. (kg) | |
| | | | | 1.9 | |

FEATURE



Stainless Connector

Patented Leak Safe Technology with Welded 304 Stainless Steel Connector.

PP Liner

FDA Polypropylene Liner

Air-Seal Diaphragm

NSF Certified Butyl Rubber Diaphragm 100% Air Seal.

Welding Zone

Pressure Equipment Directive certified Welding Structure.

Coating

Triple Coating Rust Protection.

Air Valve

Patented Air Valve Structure Cover with O-ring Seal Cap.

Pressure Tank



1 Applewood Cres., Unit 8, Vaughan, ON L4K 4K1
TEL 1-888-538-0082 / FAX 905-532-9982

